

Serie KT-WK



**INTERPUMP
GROUP**



Pratissoli

**KT16 - KT19 - KT20 - KT22
WK525 - WK531**



Manuale uso e manutenzione

Use and Maintenance Manual

Manuel d'utilisation et d'entretien

Betriebs- und Wartungsanleitung

Manual de Uso y mantenimiento

Manual de uso e manutenção

Руководство по эксплуатации и техническому обслуживанию

使用和保养手册

Kullanma ve bakım kılavuzu

دليل الاستخدام والصيانة

Contents

1	INTRODUCTION	21
2	DESCRIPTION OF SYMBOLS	21
3	SAFETY	21
3.1	General safety warnings.....	21
3.2	Essential safety in the high pressure system.....	21
3.3	Safety during work.....	21
3.4	Rules of conduct for the use of lances.....	21
3.5	Safety during system maintenance.....	22
4	PUMP IDENTIFICATION	22
5	TECHNICAL CHARACTERISTICS	22
6	DIMENSIONS AND WEIGHT	23
7	OPERATING INSTRUCTIONS.....	23
7.1	Water temperature.....	23
7.2	Maximum pressure and flow rate.....	23
7.3	Minimum operating speed.....	23
7.4	Sound emission.....	23
7.5	Vibration.....	23
7.6	Brands and types of oils recommended.....	23
8	PORTS AND CONNECTIONS	25
9	PUMP INSTALLATION	25
9.1	Installation.....	25
9.2	Rotation direction.....	26
9.3	Version change.....	26
9.4	Hydraulic connections.....	26
9.5	Pump supply.....	26
9.6	Suction line.....	26
9.7	Filtration.....	27
9.8	Outlet line.....	28
9.9	Calculation of the internal diameter of the duct pipes.....	28
9.10	V-belt transmission.....	28
9.11	Transmission definition.....	29
9.12	Definition of static pull to apply on belts.....	31
9.13	Transmission of power from the second PTO.....	31
10	START-UP AND OPERATION	31
10.1	Preliminary checks.....	31
10.2	Start-up.....	32
11	PREVENTIVE MAINTENANCE	32
12	PUMP STORAGE	32
12.1	Long-term inactivity.....	32
12.2	Method for filling pump with anti-corrosion emulsion or anti-freeze solution.....	32
13	PRECAUTIONS AGAINST FROST.....	32
14	WARRANTY CONDITIONS.....	33
15	OPERATING FAULTS AND THEIR POSSIBLE CAUSES	33
16	EXPLODED DRAWING AND PARTS LIST.....	34
17	FLUSHING CIRCUIT DIAGRAM OF USE.....	36
18	DECLARATION OF INCORPORATION	37

1 INTRODUCTION

This manual describes the instructions for use and maintenance of KT-WK HIGH-PRESSURE version pumps and should be carefully read and understood before using the pump.

Proper pump operation and duration depend on the correct use and maintenance.

Interpump Group disclaims any responsibility for damage caused by negligence or failure to observe the standards described in this manual.

Upon receipt, check that the pump is intact and complete. Report any faults before installing and starting the pump.

2 DESCRIPTION OF SYMBOLS

Read the contents of this manual carefully before each operation.



Warning Sign



Read the contents of this manual carefully before each operation.



Danger Sign

Danger of electrocution.



Danger Sign

Wear a protective mask.



Danger Sign

Wear protective goggles.



Danger Sign

Put on protective gloves before each operation.



Danger Sign

Wear appropriate footwear



Symbol for protection against explosion.

This defines special safety requirements for the use of the pumps in areas identified in accordance with the ATEX Directive.

When pumps are ordered in the ATEX configuration because they are going to work in areas with a potentially explosive atmosphere, you must **STRICTLY comply with the notes given under the headings marked with this symbol and the instructions in the supplementary instructions manual "ATEX EXPLOSION PROTECTION"**.

3 SAFETY

3.1 General safety warnings

Improper use of pumps and high pressure systems as well as non-compliance with installation and maintenance standards can cause serious damage to people and/or property. Anyone assembling or using high pressure systems must possess the necessary competence to do so, knowing the characteristics of the components to be assembled/used and taking all the necessary precautions to ensure maximum safety in all conditions of use. In the interest of safety, both for the Installer and the Operator, no reasonably applicable precaution should be omitted.

3.2 Essential safety in the high pressure system

1. The pressure line must always be provided with a safety valve.
2. High pressure system components, particularly for systems that operate primarily outside, must be adequately protected from rain, frost and heat.
3. The electrical control system must be adequately protected against sprays of water and must meet specific regulations in force.
4. The high pressure pipes must be properly sized for maximum operating pressure of the system and always used within the operating pressure range specified by the Manufacturer of the pipe itself. The same rules should be observed for all other auxiliary systems affected by high pressure.
5. The ends of high pressure pipes must be sheathed and secured in a solid structure, to prevent dangerous whiplash in case of bursting or broken connections.
6. Appropriate protective casing must be provided in pump transmission systems (couplings, pulleys and belts, auxiliary power outlets).

3.3 Safety during work



The room or area within which the high pressure system operates must be clearly marked and prohibited to unauthorized personnel and, wherever possible, segregated or fenced to ensure restricted access. Personnel authorized to access this area should first be instructed how to operate within this area and informed of the risks arising from high pressure system defects or malfunctions.

Before starting the system, the Operator is required to verify that:

1. The high pressure system is properly powered, see chapter 9 par. 9.5.
2. The pump suction filters are perfectly clean; it is appropriate to include a device indicating the clogging level on all devices.
3. Electrical parts are adequately protected and in perfect condition.
4. The high pressure pipes do not show signs of abrasion and the fittings are in perfect order.
5. In relation to the application, use and environmental conditions, during the operation the outer surfaces of the pump may reach high temperatures. Therefore we recommend to take precautions to avoid contact with hot parts.

Any fault or reasonable doubt that may arise before or during operation should be promptly reported and verified by qualified personnel. In these cases, pressure should be immediately cleared and the high pressure system stopped.

3.4 Rules of conduct for the use of lances



1. The operator must always place his safety and security first, as well as that of others that may be directly affected by his/her actions, or any other assessments or interests. The operator's work must be dictated by common sense and responsibility.

- The operator must always wear a helmet with a protective visor, waterproof gear and wear boots that are appropriate for use and can ensure a good grip on wet floors.

Note: *appropriate clothing will protect against sprays of water but not from direct impact with jets of water or very close sprays. Additional protections may therefore be necessary in certain circumstances.*

- It is good practice to organize personnel into teams of at least two people capable of giving mutual and immediate assistance in case of necessity and of taking turns during long and demanding operations.
- The work area jet range must be absolutely prohibited to and free from objects that, inadvertently under a pressure jet, can be damaged and/or create dangerous situations.
- The water jet must always and only be pointed in the direction of the work area, including during preliminary tests or checks.
- The operator must always pay attention to the trajectory of debris removed by the water jet. Where necessary, suitable guards must be provided by the Operator to protect anything that could become accidentally exposed.
- The operator should not be distracted for any reason during work. Workers needing to access the operating area must wait for the Operator to stop work on his/her own initiative, after which they should immediately make their presence known.
- It is important for safety that all team members are always fully aware of each other's intentions in order to avoid dangerous misunderstandings.
- The high pressure system must not be started up and run under pressure without all team members in position and without the Operator having already directed his/her lance toward the work area.

3.5 Safety during system maintenance

- High pressure system maintenance must be carried out in the time intervals set by the manufacturer who is responsible for the whole group according to law.
- Maintenance should always be performed by trained and authorized personnel.
- Assembly and disassembly of the pump and the various components must only be carried out by authorized personnel, using appropriate equipment in order to prevent damage to components, in particular to connections.
- Always only use original spare parts to ensure total reliability and safety.

5 TECHNICAL CHARACTERISTICS

Model	Rpm	Flow rate		Pressure		Power	
		l/min	Gpm	bar	psi	kW	HP
KT 16	1750	27.4	7.24	500	7250	26.2	35.6
KT 19	1450	30	7.90	500	7250	28.7	39
	1750	36	9.5	400	5800	27.9	38
KT 20	1450	35.5	9.40	400	5800	27.1	36.9
	1750	42.9	11.33	320	4640	26.2	35.6
KT 22	1450	43.0	11.36	320	4640	26.3	35.7
	1750	51.9	13.70	250	3625	24.8	33.7
WK525	1450	22	5.80	500	7250	21.03	28.6
WK531	1450	30	7.90	500	7250	28.7	39

4 PUMP IDENTIFICATION

Each pump has its own Serial No. XX.XXX.XXX see pos. ① and an identification plate see pos. ② in Fig. 1 which shows:

- Pump model and version
- Max revs
- Absorbed power HP - kW
- Pressure bar - P.S.I.
- Flow rate l/min - Rpm

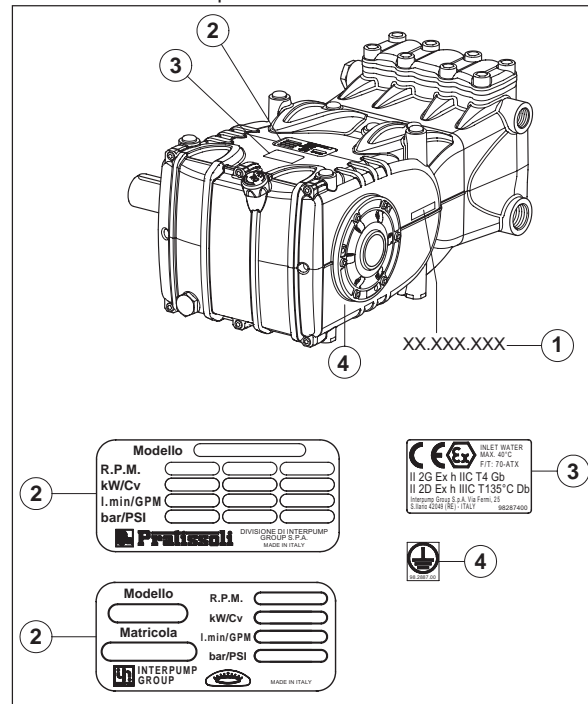

Fig. 1



For pumps ordered with the ATEX configuration.

Pos. ③ plate **with specific ATEX marking for explosion protection.**

Pos. ④ plate for locating the **grounding screw.**



Model, version and serial number must always be indicated when ordering spare parts

6 DIMENSIONS AND WEIGHT

For Standard Version pump dimensions and weight, refer to Fig. 2.

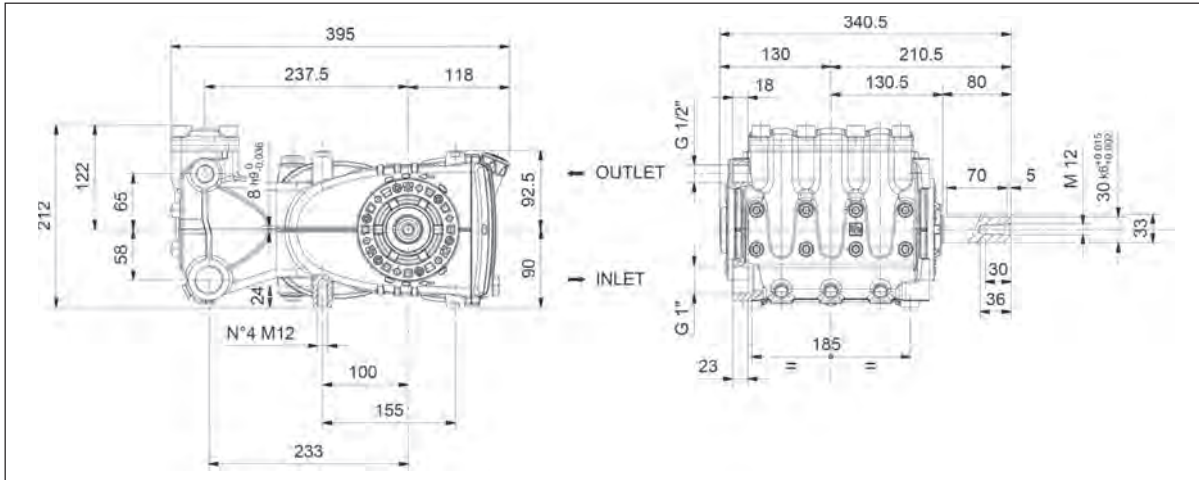

Dry weight 39 kg.

Fig. 2

7 OPERATING INSTRUCTIONS



The KT HIGH PRESSURE version pumps have been designed to operate in environments with atmospheres that are not potentially explosive, with filtered water (see par. 9.7) and at a maximum temperature of 40 °C. Other liquids can be used only upon formal approval by the **Engineering Department** or **Customer Service Department**.

7.1 Water temperature



The maximum permissible water temperature is 40 °C. However, the pump can be used with water up to a temperature of 60 °C, but only for short periods. In this case, it is best to consult the **Technical** or **Customer Service Departments**.

7.2 Maximum pressure and flow rate

The rated specifications stated in our catalog are the max. that can be obtained by the pump. **Independently** of the power used, the maximum pressure and rpm indicated on the specification label can never be exceeded unless prior formal authorization is given by our **Technical** or **Customer Service Departments**.

7.3 Minimum operating speed

The minimum rotating speed of the pump is 100 rpm, any lower minimum speed must be expressly authorized by our **Technical** or **Customer Service Departments**.

7.4 Sound emission

The sound pressure detection test was performed according to Directive 2000/14 of the European Parliament and Council (Machinery Directive) and EN-ISO 3744-1995 with class 1 instrumentation.

A final detection of sound pressure must be performed on the complete machine/system.

Should the operator be located at a distance of less than 1 meter, he will have to use appropriate hearing protection according to current regulations.

7.5 Vibration

The detection of this value shall be carried out only with the pump set up on the plant and at the performance declared by the customer.

Values must be in accordance with regulations.





7.6 Brands and types of oils recommended

The pump is supplied with oil suitable for room temperatures from 0 °C to 30 °C.

Some types of recommended oil are indicated in the table below, these oils have additives to increase corrosion resistance and fatigue resistance (DIN 51517 part 2).

Alternatively you can also use Automotive Gear SAE 85W-90 oil for gearing lubrication.

Manufacturer	Lubricant
	AGIP ACER220
	Aral Degol BG 220
	BP Energol HLP 220
	CASTROL HYSPIV VG 220 CASTROL MAGNA 220
	Falcon CL220
	ELF POLYTELIS 220 REDUCTELF SP 220
	NUTO 220 TERESSO 220
	FINA CIRKAN 220
	RENOLIN 212 RENOLIN DTA 220
	Mobil DTE Oil BB

Manufacturer	Lubricant
	Shell Tellus Öl C 220
	Wintershall Ersolon 220 Wintershall Wiolan CN 220
	RANDO HD 220
	TOTAL Cortis 220

Check the oil level and top up if necessary.

Using the oil dipstick pos. ①, Fig. 3.

The correct checking of the oil level is made with the pump not running, at room temperature. The oil change must be made with the pump at working temperature, removing: the oil dipstick, pos. ①, and then the plug pos. ②, Fig. 3.

The oil check and change must be carried out as indicated in the table in Fig. 14 chapter 11.

The quantity required is ~ 2 liters.



Set up the plant so that the oil temperature does not exceed in any case **100 °C** (212 °F) during pump operation.

Use a temperature probe to be inserted into the oil drain plug pos. ② Fig. 3.

See "ATEX EXPLOSION PROTECTION" manual.

ATTENTION: Use only oil with a flash point higher than 200 °C.

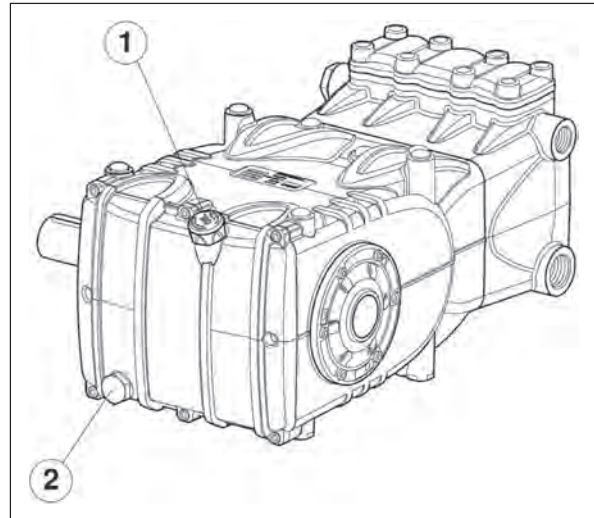

Fig. 3



In any case the oil must be changed at least once a year, as it is degraded by oxidation.

For a room temperature other than between 0 °C - 30 °C, follow the instructions in the following diagram, considering that oil must have a minimum viscosity of 180 cSt.

Viscosity / Room Temperature diagram
 $\text{mm}^2/\text{s} = \text{cSt}$

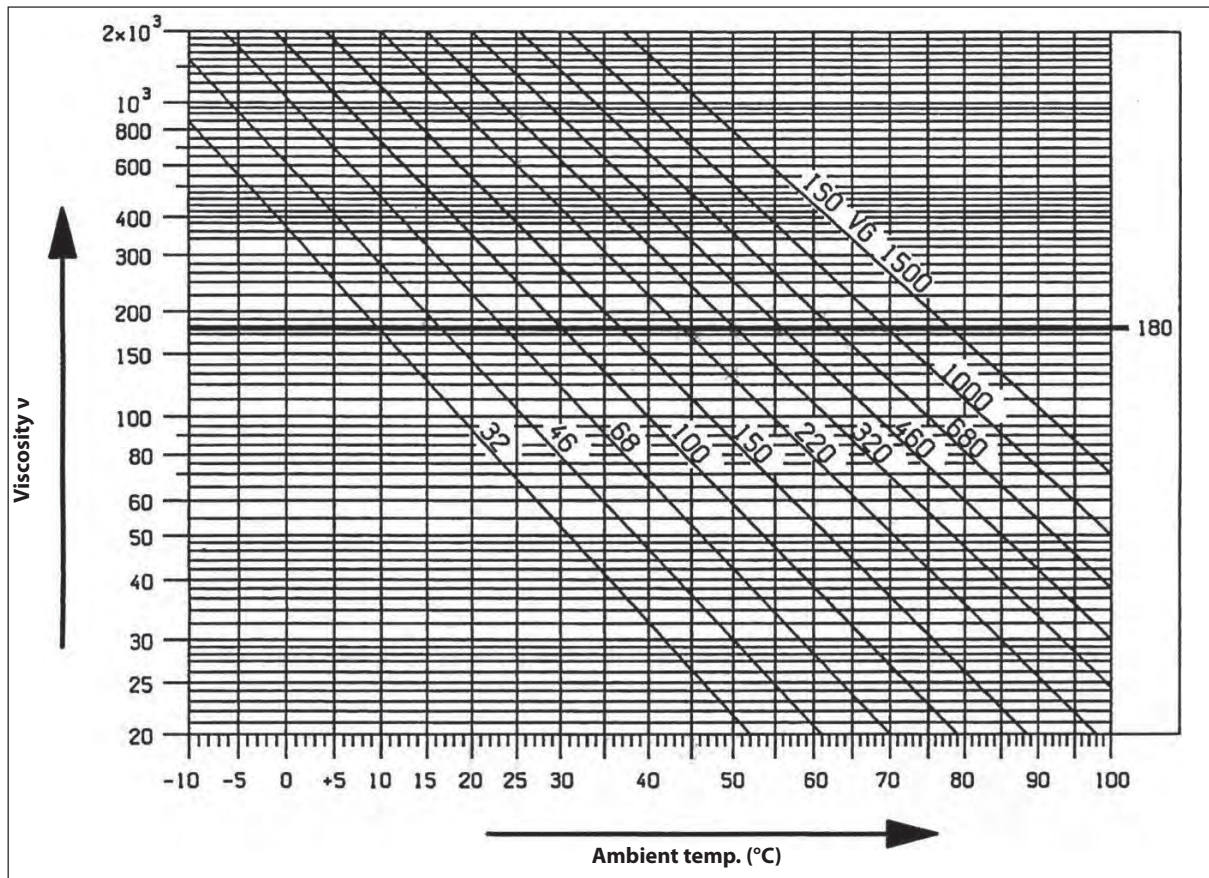

The used oil must be poured unto a suitable container and consigned to an authorized recycling center. Do not release used oil into the environment under any circumstances.

8 PORTS AND CONNECTIONS

The KE series pumps (see Fig. 4) are equipped with:

- ① No. 2 "IN" inlet ports 1" Gas.
 Line connection to any of the two ports is indifferent for proper pump functioning. The unused ports must be hermetically closed.
- ② No. 2 "OUT" outlet ports 1/2" Gas.

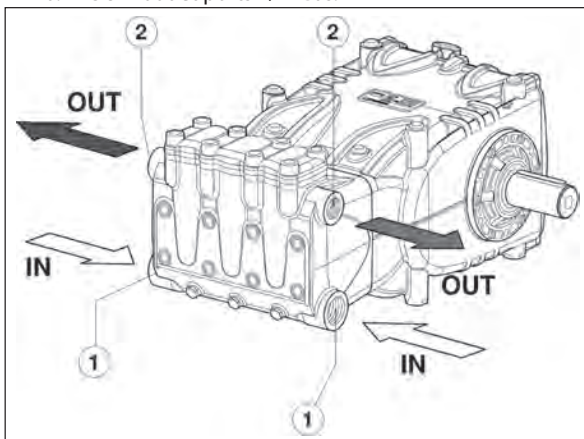

Fig. 4

9 PUMP INSTALLATION

9.1 Installation

The pump must be fixed horizontally using the M12x1.5 threaded support feet. Tighten the screws with a torque of 80 Nm.

The base must be perfectly flat and rigid enough as not to allow bending or misalignment on the pump coupling axis/transmission due to torque transmitted during operation. The unit cannot be fixed rigidly to the floor but must interposed with vibration dampers.

For special applications contact the **Technical or Customer Service Departments**.

A lifting bracket is mounted on the pump for easy installation, as per the figure below.



Should it be necessary to disassemble it, to avoid the entrance of dirt in the front part of the casing, close the threaded hole with the cap provided.



Grounding: It is necessary to fix a grounding cable to the pump by means of the M6 stainless steel screw and the stainless steel toothed washer properly marked by the YELLOW label. See "ATEX EXPLOSION PROTECTION" manual.



Replace the oil filling hole closing service plug (red) positioned on the rear casing cover. Check the correct quantity with the oil dipstick. The oil dipstick must always be reachable, even when the unit is assembled.



The pump shaft (PTO) must not be rigidly connected to the drive unit. The following types of transmission are recommended:

- Hydraulics by flange, for proper application consult with our **Technical** or **Customer Service Departments**.
- V-belts.
- Universal joint (comply with the maximum working angles recommended by the manufacturer).
- Flexible coupling.



In all cases the transmission must be assembled correctly to avoid incorrect or harsh operation of the connection parts and to prevent excessive wear, temperature rise and/or hazardous breakages that may create potential sources of ignition and explosion. See "ATEX EXPLOSION PROTECTION" manual.

9.2 Rotation direction

The rotation direction is indicated by an arrow located on the casing near the drive shaft.

From a position facing the pump head, the rotation direction will be as in Fig. 5.

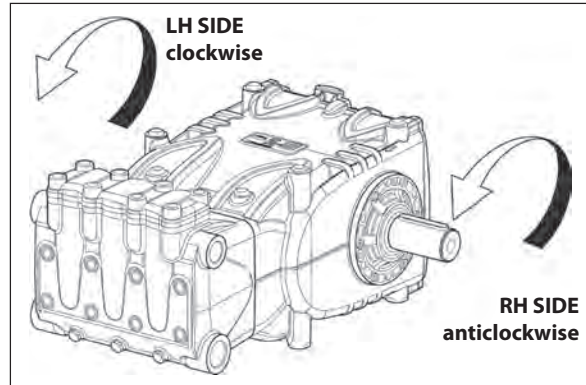

Fig. 5

9.3 Version change

The pump version is defined as right when: Observing the pump facing the head side, the pump shaft must have a PTO shank on the right side.

The pump version is defined as left when: Observing the pump facing the head side, the pump shaft must have a PTO shank on the left side.

Note. The version shown in Fig. 5 is right.



The version can only be modified by trained and authorized personnel and carefully following the instructions below:

1. Separate the hydraulic part from the mechanical part as indicated in chapter 2 par. 2.2.1 of the **Repair manual**.
 2. Turn the mechanical part 180° and reposition the rear casing cover in such a way that the oil dipstick is turned upward. Reposition the lifting bracket and relative hole closing plugs in the upper part of the casing. Finally, properly reposition the specification label in its housing on the casing.
- Make sure that the lower casing draining holes in correspondence with the pistons are open and not closed from the plastic plugs provided for the previous version.**
3. Unite the hydraulic part to the mechanical part as indicated in chapter 2 par. 2.2.5 of the **Repair manual**.



9.4 Hydraulic connections

In order to isolate the system from vibrations produced by the pump, it is advisable to make the first section of the duct adjacent to the pump (both suction and outlet) with flexible piping. The suction hose must be sufficiently rigid to prevent deformation due to the negative pressure exerted by the action of the pump.

9.5 Pump supply

A positive head of at least 0.20 metres is required for the best volumetric efficiency.



For negative prevalence contact our Technical or Customer Service Departments.

9.6 Suction line

For smooth operation of the pump, the suction line must have the following characteristics:

1. Minimum internal diameter as indicated in the graph in par. 9.9 and in any case equal to or exceeding that of the pump head.



Localized restrictions should be avoided along the piping, as these can cause pressure drops resulting in cavitation. Avoid 90° elbows, connections with other piping, restrictions, reverse gradients, inverted U-curves and Tee connections.

2. The layout must be such as to prevent cavitation problems.
3. Completely airtight and constructed to ensure a perfectly hermetic seal through time.
4. Prevent the pump from emptying when it is stopped, including partial emptying.
5. Do not use 3 or 4-way hydraulic fittings, adapters, swivel joints, etc. as they could jeopardize pump performance.

6. Do not install Venturi tubes or injectors for detergent suction.
7. Avoid use of foot valves or other types of unidirectional valves.
8. Do not recirculate the by-pass valve drain directly to the suction line.
9. Provide for proper guards inside the tank to prevent that water flow from the bypass and the tank supply line can create vortices or turbulence near the pump supply pipe port.
10. Make sure the suction line is thoroughly clean inside before connecting it to the pump.

9.7 Filtration

1 filter must be installed on the pump suction line, positioned as indicated in Fig. 6 and Fig. 6/a.

With a manually activated control valve

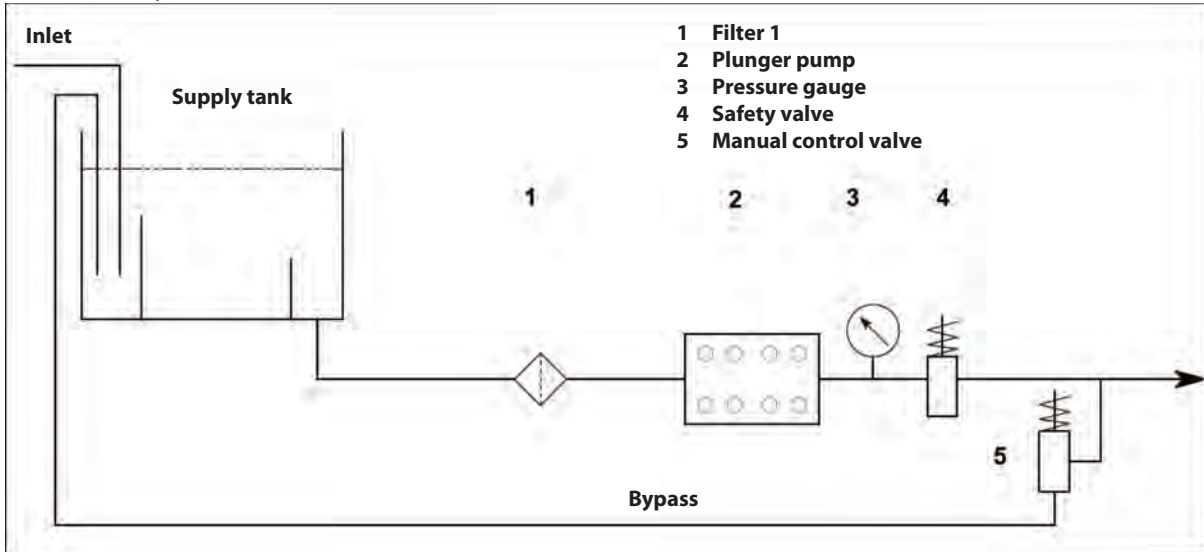

Fig. 6

With pneumatic control valve

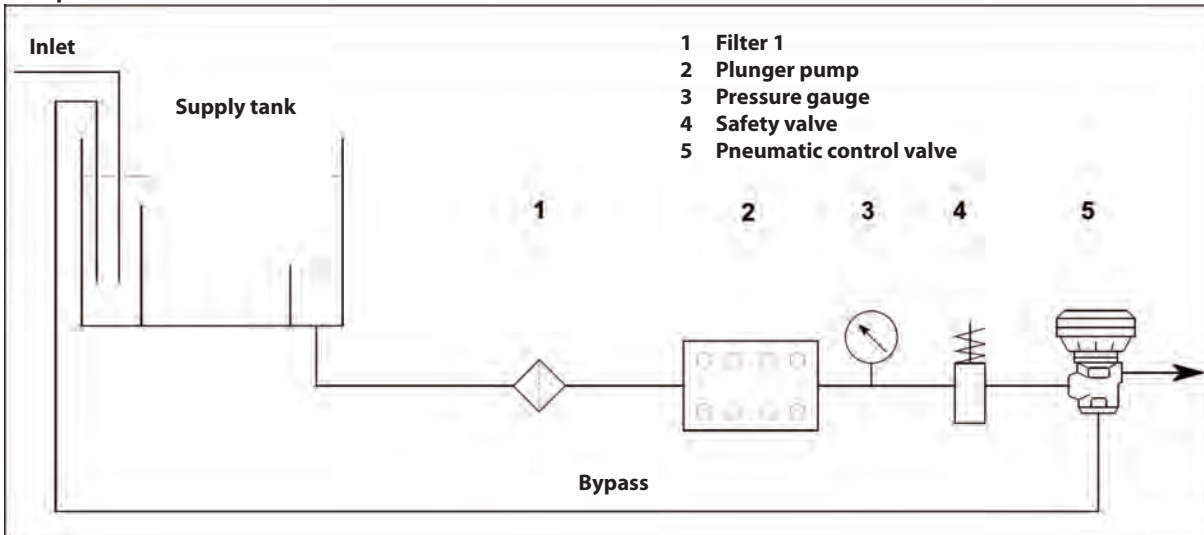

Fig. 6/a

The filter, which is to be installed as close to the pump as possible, must be easily inspectable and have the following specifications:

1. Minimum flow rate at least 3 times the nominal flow rate of the pump.
2. Inlet/outlet port diameters no smaller than the inlet port diameter of the pump.
3. Filtration grade between 200 and 360 μm .



For smooth pump operation, regular filter cleaning is necessary, planned according to the actual use of the pump in relation to the quality of water used and actual clogging conditions.

9.8 Outlet line

For correct design of the outlet line comply with the following installation prescriptions:

1. The internal diameter of the pipe must be sufficient to ensure correct fluid velocity, see graph in par. 9.9.
2. The first section of the line connected to the pump outlet must be a flexible hose, in order to isolate vibration produced by the pump from the rest of the system.
3. Use high pressure pipes and fittings to ensure high safety margins in all operating conditions.
4. The outlet line must always be provided with a Max. pressure valve.
5. Use pressure gauges capable of withstanding the pulsating loads typical of plunger pumps.
6. During the design stage, keep in mind the line pressure drops that lead to a pressure reduction at the user with respect to the pressure measured on the pump.
7. For those applications where pulses produced by the pump on the outlet line may prove harmful or unwanted, install a pulsation dampener of sufficient size.

9.9 Calculation of the internal diameter of the duct pipes

To determine the internal diameter of the duct, refer to the following diagram:

Suction duct

With a flow rate of ~ 52 l/min and a water velocity of 0.5 m/sec. The graph line joining the two scales meets the central scale showing the diameters, corresponding to a value of ~ 45 mm.

Outlet duct

With a flow rate of ~ 52 l/min and a water velocity of 5.5 m/sec. The graph line joining the two scales meets the central scale showing the diameters, corresponding to a value of ~ 16 mm.

Optimal speeds:

- Suction: ≤ 0.5 m/sec.
- Outlet: ≤ 5 m/sec.

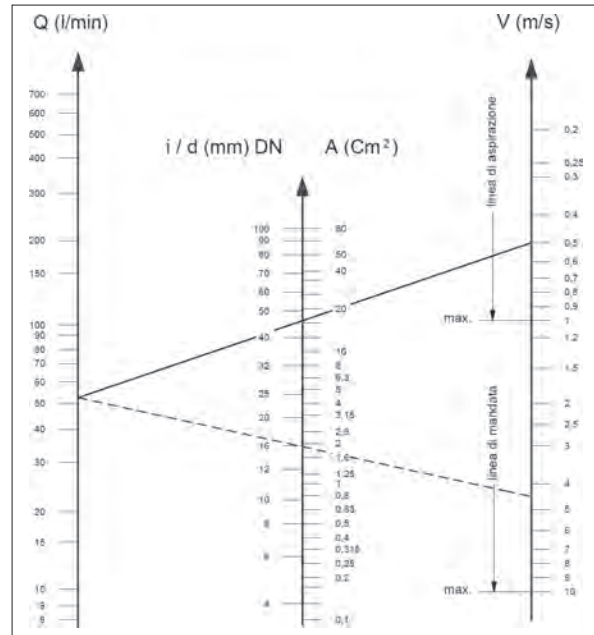

The graph does not take into account pipe resistance, valves, load loss produced by the length of the ducts, the viscosity of the liquid pumped or the temperature itself.

If necessary, contact our **Technical** or **Customer Service Departments**.

9.10 V-belt transmission

The pump can be controlled by a V-belt system.

For these pump models, we recommend to use No. 3 XPB belts (16.5x13 serrated). Use an XPC profile only for long durations. Both the characteristics and transmissible power of each belt can be verified in the diagram in Fig. 7, in relation to the number of rpm normally declared by the manufacturer. Minimum duct pulley diameter (on pump shaft): ≥ 160 mm. The radial load on the shaft must not exceed 4500 N (value necessary for Layout definition). The transmission is considered adequate if the load is applied to a maximum distance $a = 50$ mm from the shaft shoulder (P.T.O) as shown in Fig. 10.



For dimensions differing from those specified above, contact our **Technical** or **Customer Service Departments**.

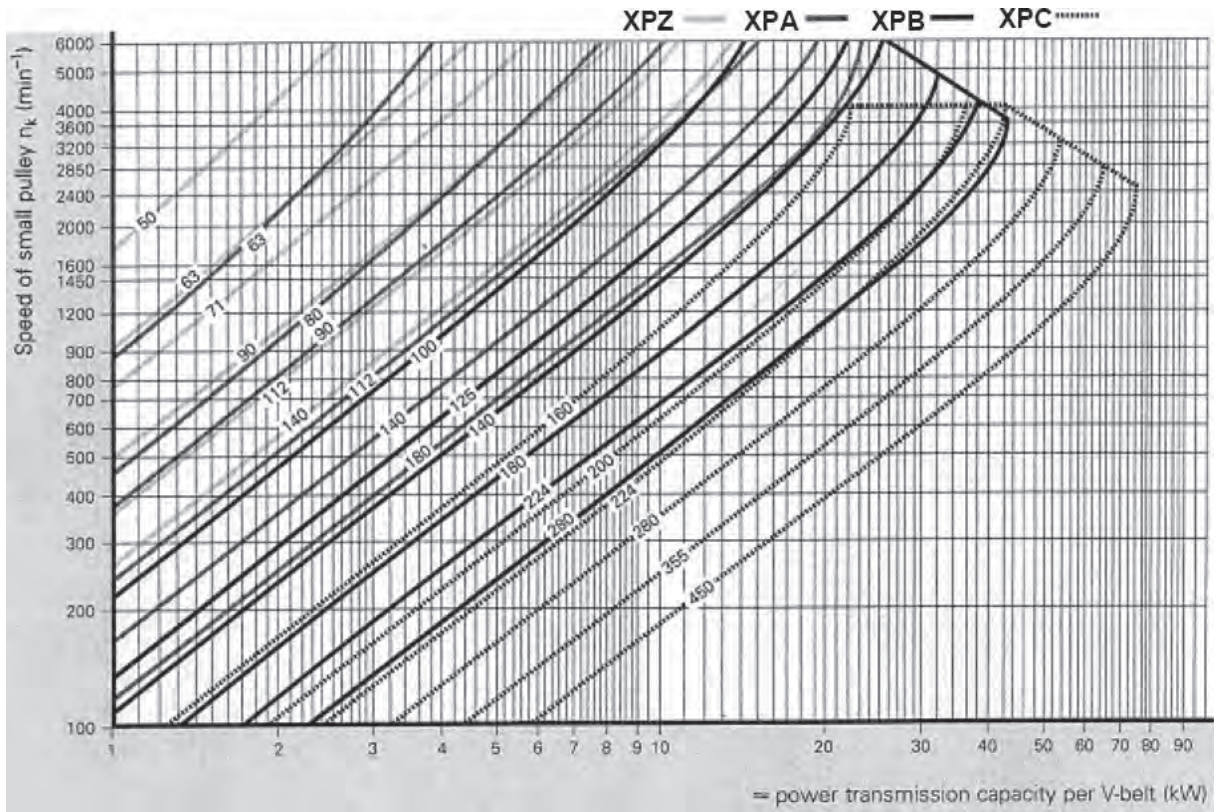

Fig. 7

9.11 Transmission definition

To prevent irregular radial loads on the shaft and the relative bearing, follow these directions:

- a) Use pulleys with V-belts with the size of the groove required/recommended by the manufacturer of belt used. In the absence of directions, follow Fig. 8 and the table in Fig. 9.

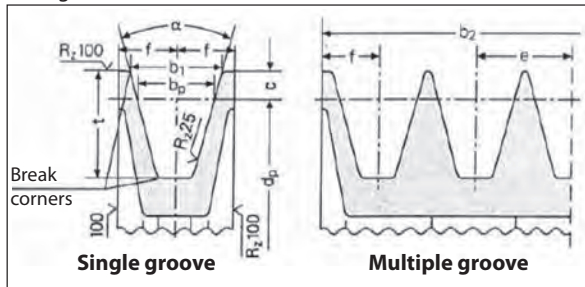

Fig. 8

Dimensions (in mm)			DIN symbol symbol B.S./ISO	XPB/SPB SPB	XPC/SPC SPC
Belt section as per DIN 7753 part 1 and B.S. 3790			DIN symbol symbol B.S./ISO	17 B	22 C
Belt section as per DIN 2215 and B.S. 3790			DIN symbol symbol B.S./ISO	17 B	22 C
Pitch width			b_w	14.0	19.0
Increased grooving width $b_1 \approx$				$\alpha = 34^\circ$	18.9
				$\alpha = 38^\circ$	19.5
			c	8.0	12.0
Distance between grooving			and	23 ± 0.4	31 ± 0.5
			f	14.5 ± 0.8	20.0 ± 1.0
Increased grooving depth			t_{min}	22.5	31.5
α	34°	by primitive diameter	d_w	from 140 to 190	from 224 to 315
	38°	narrow-section V-belts DIN 7753 part 1		> 190	> 315
α	34°	by primitive diameter	d_w	from 112 to 190	from 180 to 315
	38°	classic section V-belts DIN 2215		> 190	> 315
Tolerance for $\alpha = 34^\circ-38^\circ$				$\pm 1^\circ$	$\pm 30'$
Pulleys for b_2 by grooving number z $b_2 = (z-1) e + 2 f$			1	29	40
			2	52	71
			3	75	102
			4	98	133
			5	121	164
			6	144	195
			7	167	226
			8	190	257
			9	213	288
			10	236	319
			11	259	350
			12	282	381
Minimum pulley diameter must be respected. Do not use laminated V-belts.					

Fig. 9

- b) Use high performance belts – for example **XPB** instead of **SPB** – as a lower quantity of belts for the same transmitted power may be necessary and a consequent shorter resulting distance compared to the shaft shoulder (P.T.O) “a” of Fig. 10.

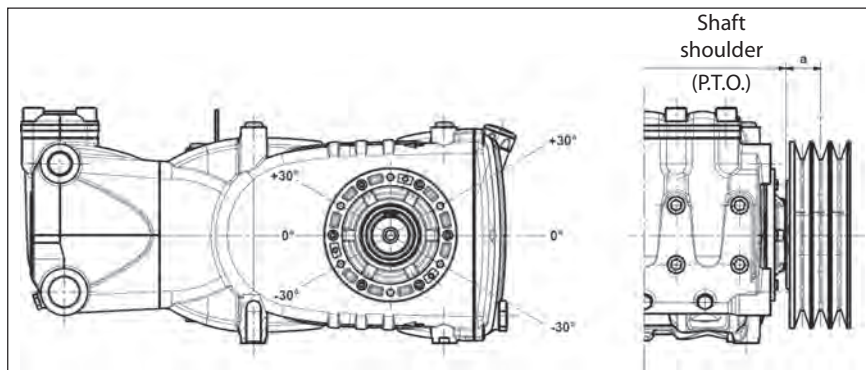

Fig. 10

- c) Pull the belts according to manufacturer instructions. Excessive pulling can cause reduced bearing life and wear out the pulley prematurely. Pulling depends on different variables as indicated in par. 9.12.
- d) Belt length has a natural tolerance $\geq \pm 0.75\%$. For this reason, the 2 belts must be purchased as a pair.
- e) Follow the direction of the belt pull as shown in Fig. 9 for other needs, contact our **Technical** or **Customer Service Departments**.
- f) Take care of the alignment of the driving pulley and driven pulley grooves.

9.12 Definition of static pull to apply on belts

Static pull depends on:

- a) The wheelbase between the two pulleys (belt length).
- b) The load due to static pull of the belt.
- c) The number of belts.
- d) The winding angle of the smallest pulley.
- e) Average speed.
- f) Etc.

Values of the static pull to be applied can be obtained from the diagram in Fig. 11 for belts with a XPB profile in relation to the wheelbase.

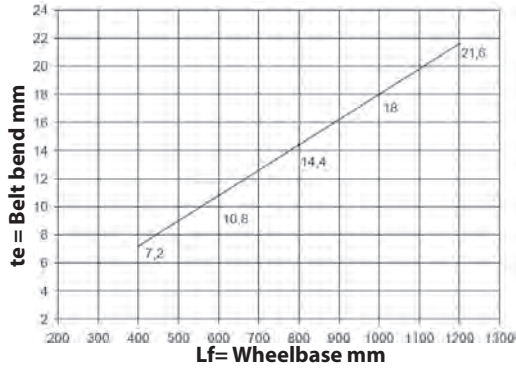
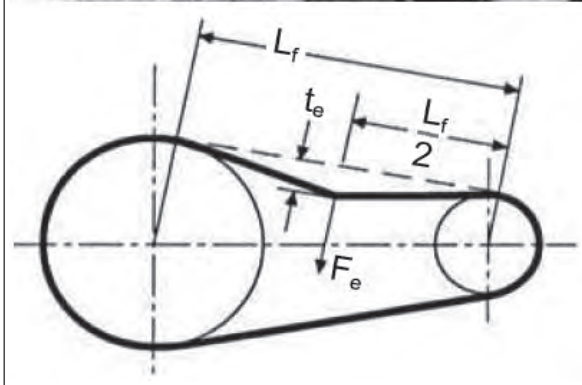
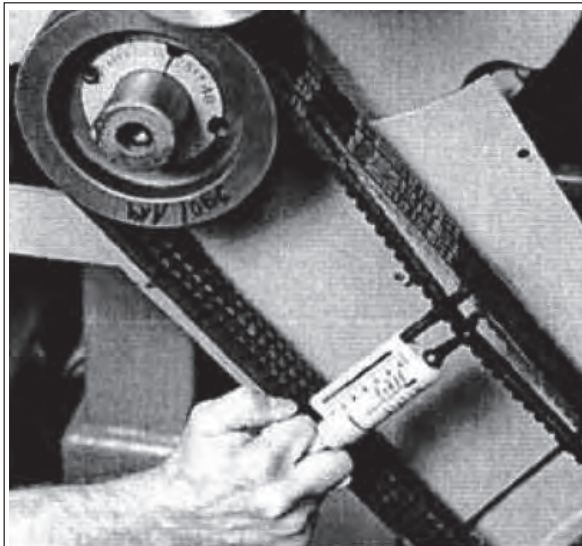

Fig. 11

Conclusion: with a wheelbase of 600 mm and with a dynamometer, loading the belt branch with 75 N as indicated in Fig. 12, a "te" bend of approximately 10.8 mm is obtained.



Lf = Wheelbase
te = Belt bend
Fe = 75 N Dynamometer load

Fig. 12

Note. Unless otherwise stated by the supplier of the belts, control of proper pull and its relative re-tensioning should be performed after no less than 30 minutes of motion necessary for the normal adjustment of the belts. Best performance and durability will be achieved with proper tensioning.

Note. In case of necessity or for routine maintenance, never replace a single belt but the complete set.

9.13 Transmission of power from the second PTO

Upon request, the KT HIGH PRESSURE version pumps can be supplied with auxiliary PTO on the side opposite of the drive (Transmission of power from the second PTO).

Transmission can be carried out:

- By means of the V-belts.
- By means of the joint.

By means of the V-Belts, withdrawable Max Torque is:

20 Nm which corresponds to:

4.1 HP at 1450 rpm;

5.0 HP at 1750 rpm.

By means of the joint, withdrawable Max Torque is:

40 Nm which corresponds to:

8.2 HP at 1450 rpm;

10 HP at 1750 rpm.

By means of the V-belt, the transmission is considered suitable if: belt pull is applied at a max distance of 18 mm with from the bend shaft shoulder (see Fig. 13). Min diameter of pulley to be used = Ø 100 mm

With transmission by means of the joint, pay particular attention to perfect alignment so that no transverse forces are generated on the pump shaft

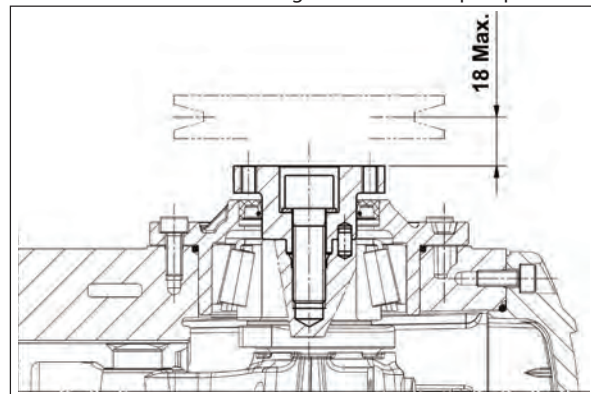

Fig. 13

For applications differing from those specified above, contact our **Technical** or **Customer Service Departments**.

10 START-UP AND OPERATION

10.1 Preliminary checks

Before start-up, ensure that:

The suction line is connected and pressurized (see par. 9.4 - 9.5 - 9.6) the pump must never run dry.

1. The suction line ensures a hermetic seal over time.
2. Any shut-off valves between the supply source and the pump are fully open. The outlet line is free discharge, to permit rapid expulsion of the air present in the pump manifold and therefore facilitate fast priming.
3. All suction and outlet fittings and connections are properly tightened.

4. The coupling tolerances on the pump/transmission axis (half-joint misalignment, Cardan joint tilt, belt pulling, etc.) remain within limits required by the transmission manufacturer.
5. Oil in the pump casing is at level, verified with a dipstick (pos. ①, Fig. 14) and exceptionally with a level indicator (pos. ②, Fig. 14).

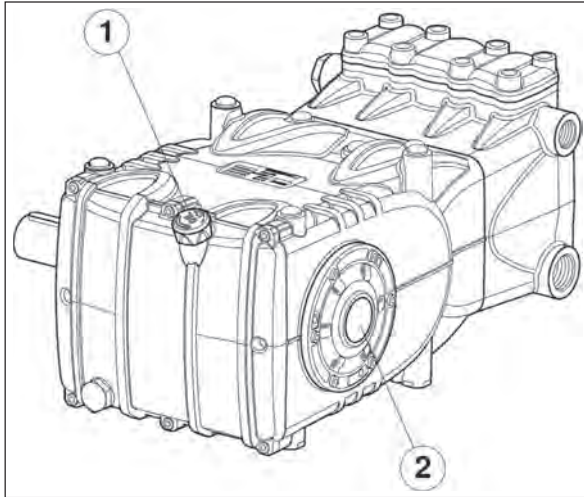

Fig. 14



In case of prolonged storage or long-term inactivity, check proper functioning of the suction and outlet valves.

10.2 Start-up

1. At first start-up, verify that the rotation direction and the supply pressure are correct.
2. Start-up the pump without any load.
3. Check that the supply pressure is correct.
4. Check that the rotation rpm during operation does not exceed the nominal rpm of the pump.
5. Let the pump run for a period of no less than 3 minutes, before putting it under pressure.
6. Before each pump stop, reset pressure by means of the control valve or with any relieving devices and reduce to a minimum rpm (activation with combustion motors).

11 PREVENTIVE MAINTENANCE

For pump reliability and efficiency, comply with maintenance intervals shown in the table.

PREVENTIVE MAINTENANCE	
Every 500 hours	Every 1000 hours
Check oil level	Change oil
	Check / Replace: Valves Valve seats Valve springs Valve guides
	Check / Replace*: H.P. seals L.P. seals



ATTENTION: Replace the bearings and the related seal rings every 2000 hours of operation.

Perform periodical checks on cleaning and maintenance on the pump. See "ATEX EXPLOSION PROTECTION" manual.

12 PUMP STORAGE

12.1 Long-term inactivity



If the pump is started for the first time after a long period from the date of shipment, before operation check the oil level, inspect the valves as specified in chapter 10, then follow described start-up procedures.

12.2 Method for filling pump with anti-corrosion emulsion or anti-freeze solution

Method for filling pump with anti-corrosion emulsion or anti-freeze solution using an external diaphragm pump based on the layout shown in par. 9.8, between pos. ① and pos. ② of Fig. 6 and Fig. 6/a:

- In place of the service tank, use a suitable container containing the solution to be pumped.
- Close the filter drainage, if open.
- Make sure that the hoses to be used are clean inside and spread grease on their connections.
- Connect the high pressure exhaust pipe to the pump.
- Connect the suction pipe to the diaphragm pump.
- Connect the suction pipe between the pump head and the diaphragm pump.
- Fill the service container with solution/emulsion.
- Insert the free ends of the suction pipes and the high pressure exhaust pipe inside the container.
- Switch on the diaphragm pump.
- Pump the emulsion until it exits from the high pressure exhaust pipe.
- Continue pumping for at least another minute.
- Stop the pump and remove the previously connected pipes.
- Clean, grease and plug the connections on the pump head.

The characteristics of the emulsion can be strengthened if necessary by adding, for example, Shell Donax.

13 PRECAUTIONS AGAINST FROST



Follow the instructions in Chapter 12 in areas and times of the year at risk of frost (see par. 12.2).



In the presence of ice, do not run the pump for any reason until the circuit has been fully defrosted, in order to avoid serious damage to the pump.

14 WARRANTY CONDITIONS

The guarantee period and conditions are contained in the purchase agreement.

The guarantee will in any case be invalidated if:

- a) The pump is used for purposes other than the agreed purposes.
- b) The pump is driven by an electric motor or internal combustion engine having performance values exceeding those shown in the table.
- c) The safety devices provided are uncalibrated or disconnected.
- d) The pump has been used with accessories or spare parts not supplied by Interpump Group.
- e) Damage has been caused by:
 - 1) improper use
 - 2) failure to follow maintenance instructions
 - 3) any use different from that described in the operating instructions
 - 4) lack of sufficient flow rate
 - 5) defective installation
 - 6) improper positioning or sizing of pipes
 - 7) unauthorized design modifications
 - 8) cavitation.

15 OPERATING FAULTS AND THEIR POSSIBLE CAUSES



The pump does not produce any noise upon start-up:

- The pump is not primed and is running dry.
- No suction water.
- Valves are jammed.
- The outlet line is closed and does not allow the release of air present in the pump manifold.



Pump pulsates irregularly:

- Air suction.
- Insufficient supply.
- Bends, elbows, fittings on the suction line are choking the passage of liquid.
- Suction filter is dirty or too small.
- The booster pump, where installed, is supplying insufficient pressure or flow rate.
- The pump is not primed due to insufficient head or the outlet is closed during priming.
- The pump is not primed due to valve jamming.
- Worn valves.
- Worn pressure seals.
- Imperfect functioning of the pressure control valve.
- Problems on the transmission



The pump does not supply the nominal flow rate/excessive noise:

- Insufficient supply (see various causes as above).
 - Pump speed is below the rated speed;
- 
- Excessive internal leakage of pressure control valve.
 - Worn valves.
 - Excessive leakage from the pressure seals.
 - Cavitation due to:
 - 1) Improper sizing of suction ducts/undersized diameters.
 - 2) Insufficient flow rate.
 - 3) High water temperature.



The pressure supplied by the pump is insufficient:

- The user flow (nozzle) is or has become greater than the pump capacity.
- Insufficient revolutions per minute.
- Excessive leakage from the pressure seals.
- Imperfect functioning of the pressure control valve.
- Worn valves.



Pump overheats:

- The pump is working in overpressure conditions or pump rpm is higher than the nominal value.
- Oil in the pump casing is not at level or not the recommended type as detailed in chapter 7 (see par. 7.6).
- Excess belt tension or joint or pulley alignment is incorrect.
- Excessive pump tilt during operation.



Vibrations or hammering on pipes:

- Air suction.
- Faulty operation of pressure control valve.
- Valves malfunction.
- Non-uniformity of transmission motion.

16 EXPLODED DRAWING AND PARTS LIST

Flangia tipo "A" per azionamenti diretti
OPTIONAL

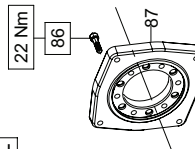

22 Nm 86 87

Campana e Giunto per accoppiamenti a motori idraulici SAE B
OPTIONAL

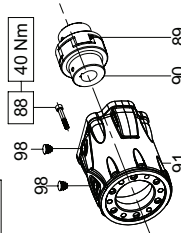

40 Nm 88 89 90 91 98

Preso di forza ausiliario su lato opposto azionamento
OPTIONAL

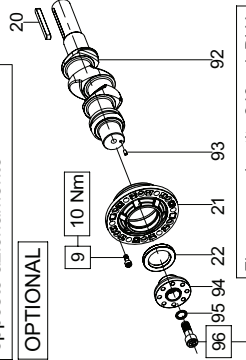

10 Nm 9 20 92 93 94 95 96

Fissare con Loctite 243 col. BLU
Cod.12.0064.00

145 Nm

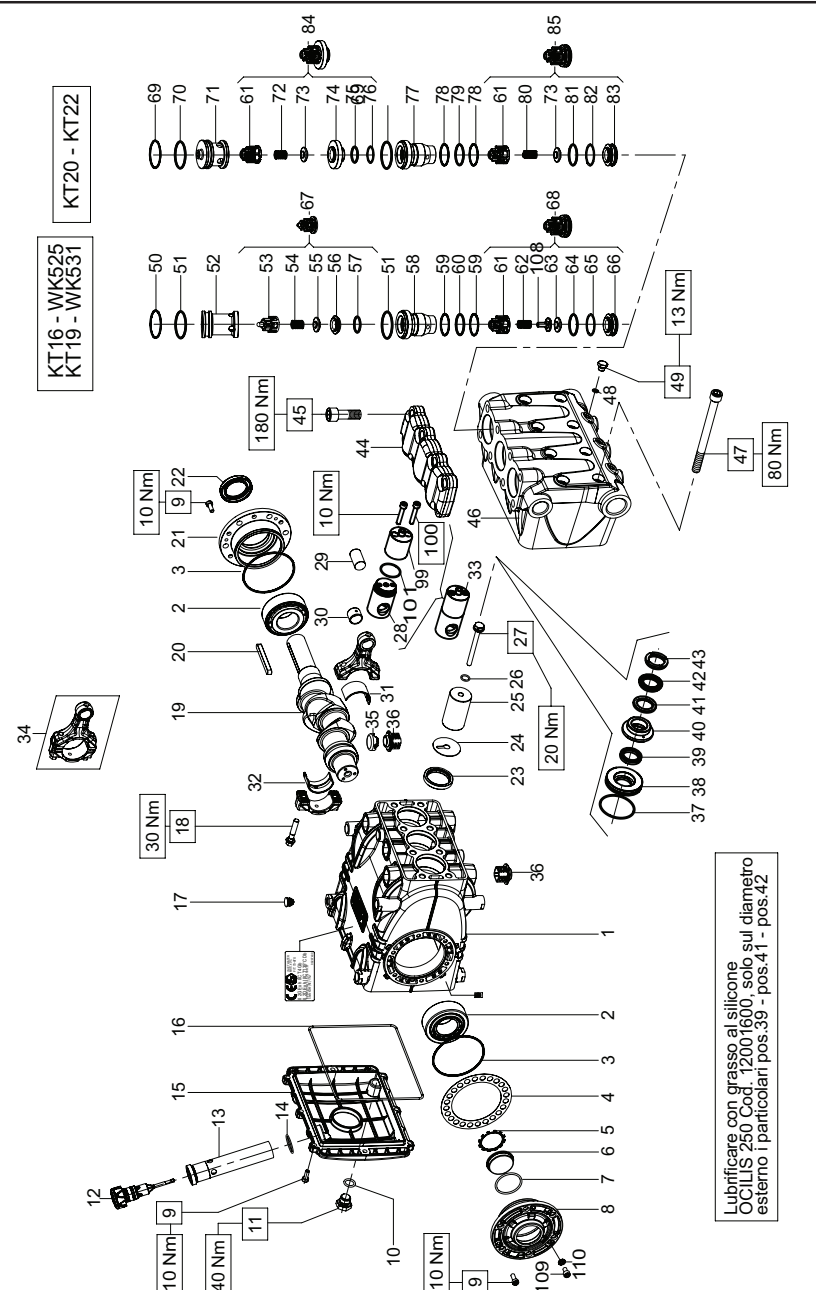

KT16 - WK525
KT19 - WK531

KT20 - KT22

KT HP

DIS. COD. 70.9513.00_07

Lubrificare con grasso al silicone
 OCILLIS F50 Cod.2001600; Solo sul diametro
 esterno. I particolari pos.39 - pos.41 - pos.42

Flangia per accoppiamenti diretti a motori idraulici SAE B
OPTIONAL

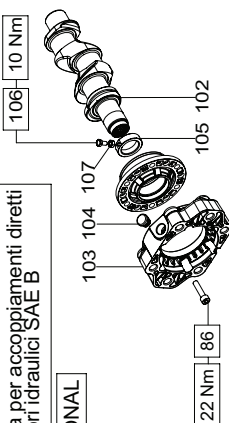

22 Nm 86 103 104 105 106 107

Sistema Flussaggio tenute
OPTIONAL

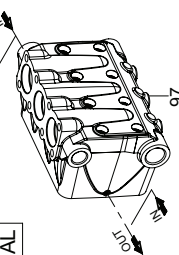

97

KIT RICAMBIO – SPARE KIT

A	Kit tenute pompanti – Plunger packing kit	KT16 WK525 (D.16)	KT19 WK531 (D.19)	KT20 (D.20)	KT22 (D.22)
B	Kit valvole aspirazione – In valves kit	KIT 2227	KIT 2408	KIT 2229	KIT 2230
C	Kit valvole mandata – Out valves kit	KIT 2031	KIT 2256	KIT 2022	KIT 2023
D	Kit tenute complete – Complete seals kit	KIT 2231	KIT 2409	KIT 2233	KIT 2234
E	Kit bronzine bielle – Conrod bushing kit	KIT 2156			

WK 525	KT16
WK 531	KT20
	KT19
	KT22

POS	CODE CODICE	DESCRIPTIONE DESCRIZIONE	NR. PCS.	KIT	POS	CODE CODICE	DESCRIPTIONE DESCRIZIONE	NR. PCS.	KIT
1	70.0100.22	CARTER POMPA	1		72	94.7401.00	MOLLA Dm. 12.0x17.0 - KT20 22	3	
2	91.8477.00	CUSCINETTO RULLI	2	A-D	73	36.2039.66	VALVOLA SFERICA - KT20 22	6	
3	90.3915.00	OR D. 80.60x2.62 NBR 70SH 3318	2	D	74	36.2043.66	SEDE VALVOLA - KT20 22	3	C-D
4	70.2200.81	SPRESSORE DI RASAMENTO 0.10 mm.	1		75	90.3851.00	OR D. 21.89x2.62 NBR 90SH 3087 - KT20 22	3	C-D
5	90.0756.00	ANELLO D'ARRESTO 245	1	D	76	90.5145.00	ANELLO ANTIEST. D. 22.9x27.0x1.5 - KT20 22	3	
6	70.2118.01	SPINA LIVELLO OLIO	1		77	70.2244.66	BUSSOLA VALVOLE - KT20 22	3	D
7	90.3877.00	OR D. 39.34x2.62 NBR 70SH	1	D	78	90.5179.00	ANELLO ANTIEST. D. 31.4x35.5x1.5 - KT20 22	6	D
8	70.1501.22	COPERCHIO CUSCINETTO LATO SPIA	1		79	90.3866.00	OR D. 29.82x2.62 NBR 90SH 3118 - KT20 22	3	D
9	90.1854.00	VITE M6x16 5931	20		80	94.7397.00	MOLLA Dm. 11.4x20.0 - KT20 22	3	B-D
10	90.3833.00	OR D. 13.95x2.62 NBR 70SH 3056	1	D	81	90.5177.00	ANELLO ANTIEST. D. 30.0x34.5x1.5 - KT20 22	3	D
11	98.2100.30	TAPPO G 3/8x13 TE22 - ZINC.	1		82	36.2042.66	SEDE VALVOLA - KT20 22	3	C
12	98.2115.00	TAPPO CON ASTA D. 21.5x70.0	1		83	36.7139.01	GR. VALVOLA DI MANDATA - KT20 22	3	B
13	72.2106.95	TUBO PER ASTA LIVELLO OLIO	1		84	36.7138.01	GR. VALVOLA D'ASPIRAZIONE - KT20 22	3	B
14	90.3604.00	OR D. 25.12x1.78 NBR 70SH 2100	1	D	85	90.0502.66	STELO GUIDA PISTONE	3	B
15	70.1606.22	COPERCHIO CARTER	1		86	99.1925.00	VITE M6x35 5931	6	D
16	90.3942.00	OR D. 190.17x2.62 NBR 70SH 3750	1	D	87	10.0673.20	FLANGIA MOTORE IDR. TIPO A	1	
17	98.2005.00	TAPPO PER FORO D. 15	5		88	99.3084.00	VITE M8x30 5931	6	
18	99.3123.00	VITE SERRAGGIO BIELLA	6		89	10.0755.47	ELEMENTO ELASTICO GIUNTO DI. 46	1	
19	70.0206.35	ALBERO A GOMITI C. 26	1		90	10.7430.01	GIUNTO ELASTICO D. 30x25.4	1	
20	91.4900.00	LINGUETTA 8.0x7.0x7.0	1		91	10.0752.20	FLANGIA MOTORE IDR. SAE-B	1	
21	70.1500.22	COPERCHIO CUSCINETTO LATO PTO	1		98	98.2060.00	TAPPO PER FORO D. 15	2	
22	90.1668.00	ANELLO RAD. D. 35.0x52.0x7.0	1	D	99	99.3136.00	VITE M8x45 5931	6	
23	90.1677.00	ANELLO RAD. D. 36.0x47.0x6.07/5	3	D	89	10.0755.47	ELEMENTO ELASTICO GIUNTO DI. 46	1	
24	96.7099.00	ROSETTA D. 10.0x45.0x1.0	3		90	10.7430.01	GIUNTO ELASTICO D. 30x25.4	1	
25	70.0418.09	PISTONE D. 16x63	3		91	10.0752.20	FLANGIA MOTORE IDR. SAE-B	1	
26	70.0400.09	PISTONE D. 20x63	3		98	98.2060.00	TAPPO PER FORO D. 15	2	
27	70.0401.09	PISTONE D. 22x63	3		99	99.1854.00	VITE M8x16 5931	6	
28	90.3584.00	OR D. 10.82x1.78 NBR 90SH 2043	3	D	90	91.4900.00	LINGUETTA 8.0x7.0x7.0	1	
29	70.2241.36	VITE FISSAGGIO PISTONE	3		91	10.1500.22	COPERCHIO CUSCINETTO LATO PTO	1	
30	70.0501.15	GUIDA PISTONE	3		92	70.1500.22	COPERCHIO CUSCINETTO LATO PTO	1	
31	90.9100.00	BOCCOLA PIEDE BIELLA	3		93	90.1668.00	ANELLO RAD. D. 35.0x52.0x7.0	1	
32	90.9220.00	SEMIBOCC. TESTA BIELLA - SUP.	3	E	94	97.6152.00	SPINA CILINDRICA D. 5.0x10.0	1	
33	90.9223.00	SEMIBOCC. TESTA BIELLA - INF.	3	E	95	97.6152.00	SPINA CILINDRICA D. 5.0x10.0	1	
34	70.0608.01	GR. GUIDA PISTONE	3		96	96.7160.00	ROSETTA D. 12.0x18.0x1.0	1	
35	70.0305.01	BIELLA	3		99	99.4295.00	VITE M12x35 5931	1	
36	71.2259.51	CAPPUCCIO TAPPO CARTER	6		86	99.3084.00	VITE M8x30 5931	6	
37	90.3626.00	OR D. 50.52x1.78 NBR 70SH 2200	3	A-D	102	70.0209.35	ALBERO A GOMITI C. 26 HYP SAE-B	1	
38	70.0823.66	ANELLO DI FONDO D. 16	3		103	10.0853.22	FLANGIA MOTORE IDR. SAE-B	1	
39	70.0819.66	ANELLO DI FONDO D. 20	3		104	90.2065.00	TAPPO PER FORO D. 17	1	
	70.0820.66	ANELLO DI FONDO D. 22	3		105	70.2267.71	ANELLO PER ALBERO D. 30 HYDR.PACK	1	
	90.2631.00	ANELLO TEN. ALT. D. 16.0x24.0x6.5 LP	3	A-D	106	70.2270.34	VITE M6x15 CON INCAVO COMPLETA	1	
	90.2662.00	ANELLO TEN. ALT. D. 19.0x27.0x5.4 LP	3	A-D	107	92.2025.00	DADO M6x5 5588	1	

17 FLUSHING CIRCUIT DIAGRAM OF USE

Adhere to the following values for proper system operation:
minimum circuit flow rate 4 l/min, maximum fluid pressure 6 bar

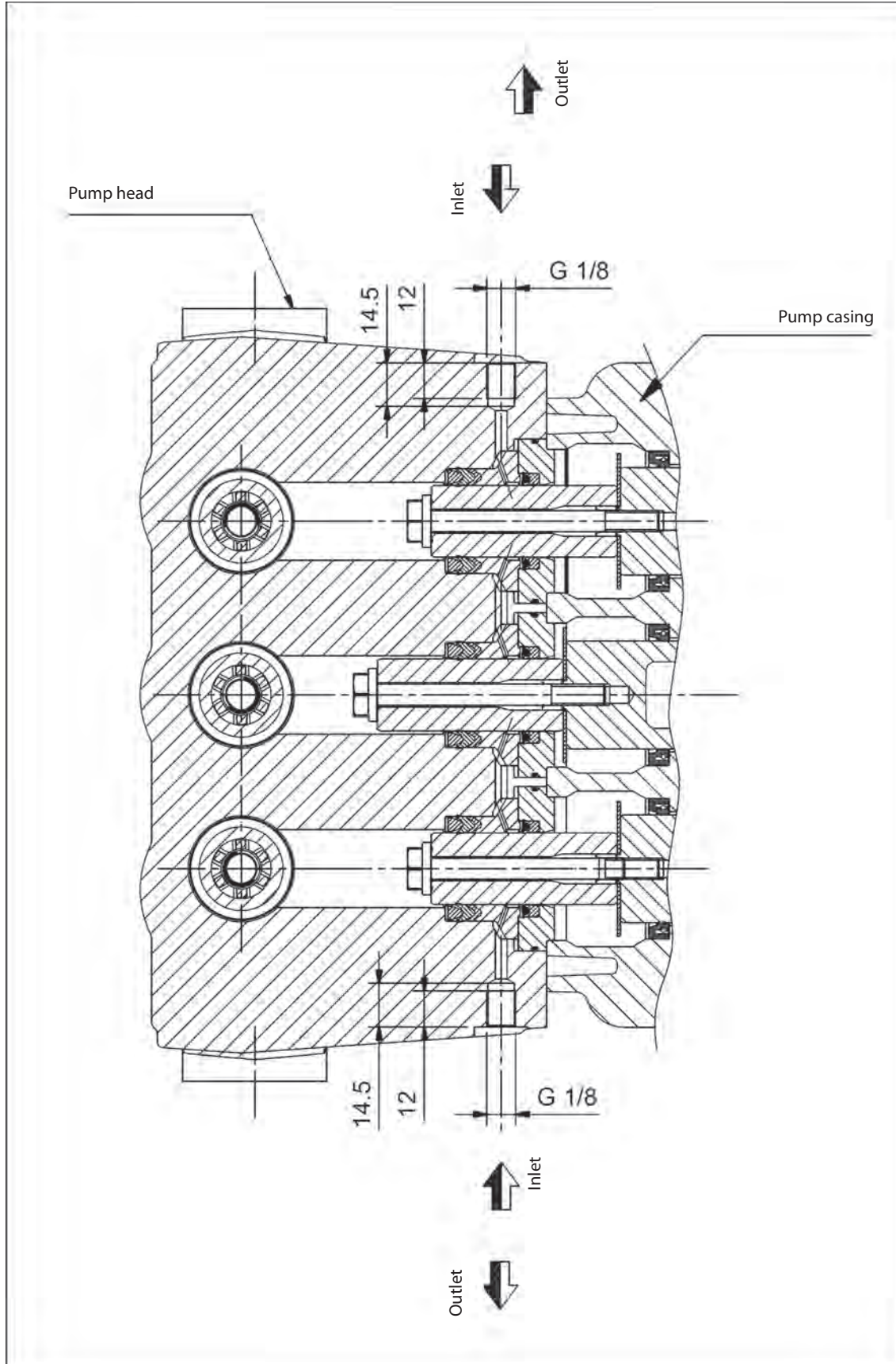

18 DECLARATION OF INCORPORATION

DECLARATION OF INCORPORATION

(In accordance with Annex II of European Directive 2006/42/EC)

The manufacturer **INTERPUMP GROUP S.p.A. - Via E. Fermi, 25 - 42049 - S. ILARIO D'ENZA - Italy** **DECLARES** that the product identified and described as follows:

Designation: Pump
Type: Reciprocating plunger pump for high pressure water
Trademark: INTERPUMP GROUP
Model: KT16 - KT19 - KT20 - KT22 - W525 - W531 series

Is found to comply with the Machinery Directive 2006/42/EC
Standards applied: UNI EN ISO 12100:2010 - UNI EN 809:2000

The pump identified above meets all the essential safety and health protection requirements as listed in section 1 of Annex I of the Machinery Directive:

1.1.1 – 1.1.2 – 1.1.3 – 1.1.5 – 1.1.6 - 1.3.1 – 1.3.2 – 1.3.3 – 1.3.4 – 1.5.4 – 1.5.5 – 1.6.1 – 1.7.1 – 1.7.2 – 1.7.4 – 1.7.4.1 – 1.7.4.2 and the relevant technical documentation has been compiled in accordance with Annex VII B.

In addition, following a motivated request the manufacturer undertakes to provide a copy of the relevant pump technical documentation in the manner and terms to be defined.

The pump should not be put into service until the plant to which the pump is to be incorporated has been declared in accordance with the provisions of the relevant directives and/or standards.

Person authorized to compile the technical file

Name: Maurizio Novelli

Address: INTERPUMP GROUP S.p.A. - Via E. Fermi, 25 -
42049 - S. ILARIO D'ENZA (RE) - Italy

The manager:

Reggio Emilia - January 2017

Ing. Massimiliano Bizzarri

