



59 series

# E3 EVOLUTION

NEW



BRASS VERSION



E3 - VH version

## ... The big technological evolution

# E3 EVOLUTION



All models can be supplied with built-in "H" type automatic pressure regulators (right).

Tous les modèles peuvent être livrés avec régulateur automatique de pression incorporé de la série "H" (à droite).

Alle Modelle sind mit eingebautem automatischem Druckregulierventil typ "H" lieferbar (rechts).

Todos los modelos (excepto modelos pueden venir equipados con regulador automatico de presión incorporado, de tipo "H" (a la derecha).

Tutti i modelli possono essere forniti con valvola di regolazione automatica incorporata di tipo "H" (a destra).

Pump type Type de pompe Pumpentype Tipo de bomba Tipo di pompa	Flow rate Débit Förderleistung Caudal Portata		Max. pressure Pression Druck Presión Pressione			r.p.m. tr./min. u.p.m. r/min. g./min.	Power Puissance Leistung Potencia Potenza		Weight Poids Gewicht Peso Peso	Dimensions Dimensions Dimension Dimensiones Dimensioni
	l/min.	G.P.M. (U.S.A.)	bar	MPa	p.s.i.		kW	hp		
<b>E3A1713</b>	13,0	3.43	170	17	2465	1000	4,19	5,7	9,5	265x223x136
<b>E3A1515</b>	14,5	3.83	150	15	2175		4,12	5,6		
<b>E3B1911</b>	11	2.91	190	19	2755	1450	3,97	5,4	9,5	265x223x136
<b>E3B1713</b>	13	3.43	170	17	2465		4,19	5,7		
<b>E3B1515</b>	15	3.96	150	15	2175		4,26	5,8		
<b>E3B1218</b>	18	4.76	120	12	1750		4,12	5,6		
<b>E3B1021</b>	21	5.55	100	10	1450		4,04	5,5		
<b>E3C1713</b>	13	3.43	170	17	2465	1750	4,19	5,7	9,5	265x223x136
<b>E3C1515</b>	15	3.96	150	15	2175		4,26	5,8		
<b>E3C1218</b>	18	4.76	120	12	1750		4,12	5,6		
<b>E3C1021</b>	21	5.55	100	10	1450		4,04	5,5		





59 series

# E3 EVOLUTION

NEW



NICKEL PLATED VERSION



E3 - VH version

## ... The big technological evolution



series

# E3 EVOLUTION



All models can be supplied with built-in "H" type automatic pressure regulators (right).

Tous les modèles peuvent être livrés avec régulateur automatique de pression incorporé de la série "H" (à droite).

Alle Modelle sind mit eingebautem automatischem Druckregulierventil typ "H" lieferbar (rechts).

Todos los modelos (excepto modelos pueden venir equipados con regulador automatico de presión incorporado, de tipo "H" (a la derecha).

Tutti i modelli possono essere forniti con valvola di regolazione automatica incorporata di tipo "H" (a destra).

Pump type Type de pompe Pumpentype Tipo de bomba Tipo di pompa	Flow rate Débit Förderleistung Caudal Portata		Max. pressure Pression Druck Presión Pressione			r.p.m. tr./min. u.p.m. r/min. g./min.	Power Puissance Leistung Potencia Potenza		Weight Poids Gewicht Peso Peso	Dimensions Dimensions Dimension Dimensiones Dimensioni
	l/min.	G.P.M. (U.S.A.)	bar	MPa	p.s.i.		kW	hp		
<b>E3A2113</b>	13,0	3.43	210	21	3045	1000	5,22	7,1	9,5	265x223x136
<b>E3A2115</b>	14,5	3.83	210	21	3045		5,81	7,9		
<b>E3B2511</b>	11	2.91	250	25	3625	1450	5,22	7,1	9,5	265x223x136
<b>E3B2513</b>	13	3.43	250	25	3625		6,18	8,4		
<b>E3B2515</b>	15	3.96	250	25	3625		7,13	9,7		
<b>E3B2118</b>	18	4.76	210	21	3045		7,21	9,8		
<b>E3B2121</b>	21	5.55	210	21	3045		8,46	11,5		
<b>E3C2513</b>	13	3.43	250	25	3625	1750	6,18	8,4	9,5	265x223x136
<b>E3C2515</b>	15	3.96	250	25	3625		7,13	9,7		
<b>E3C2518</b>	18	4.76	250	25	3625		8,60	11,7		
<b>E3C2521</b>	21	5.55	250	25	3625		10,00	13,6		
<b>E3E2813</b>	13	3.43	275	27,5	4000	3400	6,84	9,3	9,5	265x223x136
<b>E3E2815</b>	15	3.96	275	27,5	4000		7,87	10,7		
<b>E3E2517</b>	17	4.49	250	25	3625		8,09	11,01		
<b>E3E2520</b>	20	5.28	250	25	3625		9,56	13,0		

## VERSION WITH FLANGE / VERSION AVEC BRIDE AUSFÜHRUNGEN MIT FLANSCH / VERSIONE CON BRIDA VERSIONE CON FLANGIA

<b>E3E2813 C1"</b>	13	3.43	275	27,5	4000	3400	6,84	9,3	<b>C 1" Version</b>	
<b>E3E2815 C1"</b>	15	3.96	275	27,5	4000		7,87	10,7	For gasoline engine SAE J609-B ext. 4	
<b>E3E2517 C1"</b>	17	4.49	250	25	3625		8,09	11,01	Pour moteur essence SAE J609-B ext. 4	
<b>E3E2520 C1"</b>	20	5.28	250	25	3625		9,56	13,0	Für Benzinmotor SAE J609-B ext. 4	
									Para motor de gasolina SAE J609-B ext. 4	
									Per motore endotermico SAE J609-B ext. 4	



C 1" Version

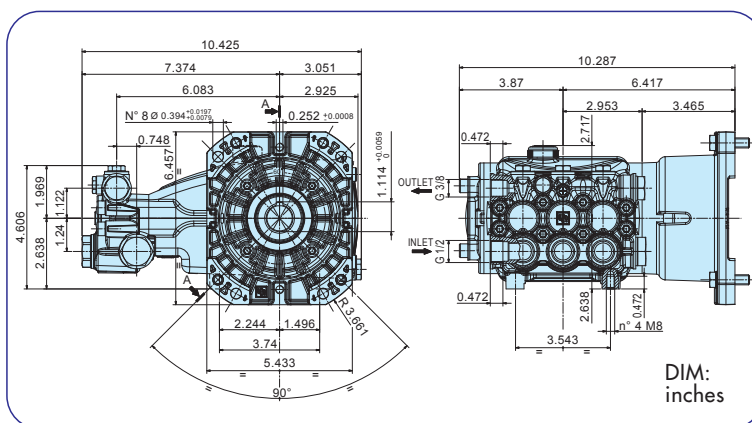



# INTERPUMPGROUP

# E3

I  
GB  
F

**ISTRUZIONI D'USO  
INSTRUCTIONS FOR USE  
MODE D'EMPLOI**

D  
E  
P

**BEDIENUNGSANLEITUNG  
INSTRUCCIONES DE USO  
INSTRUÇÕES DE USO**

Questo manuale deve essere letto e compreso in accordo al libretto generico "Istruzioni d'uso e manutenzione".  
 This manual must be read and followed in accordance with the generic "Instructions for Use and Maintenance" booklet.  
 Ce manuel doit être lu et compris en accord avec la notice générale " Mode d'emploi et d'entretien ".  
 Dieses Handbuch ist in Verbindung mit dem allgemeinen Handbuch " Gebrauchs- und Wartungsanleitung " zu lesen und zu verstehen.  
 Este manual debe leerse y comprenderse de acuerdo con el manual general "Instrucciones de uso y mantenimiento"  
 Este manual deve ser lido e interpretado de acordo com o livro genérico "Instruções de uso e manutenção"



## 59

# S E R I E S



Modello Model Modèle Modell Modelo Modelo	Portata Flow rate Débit Förderstrom Caudal Flujo		Pressione Pressure Pression Druck Presión Pressão			g/m rpm t/m upm r/m r/m	Potenza Power Puissance Leistung Potencia Poder		Peso Weight Poids Gewicht Peso Peso		
	L/min	gpm	bar	MPa	psi		Hp	kW	Kg	Ibs	
E3A1713	13.0	3.43	170	17	2465	1000	5.7	4.19	9.5	21	0.65
E3A1515	14.5	3.83	150	15	2175	1000	5.6	4.12	9.5	21	0.65
E3A2113	13.0	3.43	210	21	3045	1000	7.1	5.22	9.5	21	0.65
E3A2115	14.5	3.83	210	21	3045	1000	7.9	5.81	9.5	21	0.65
E3B1911	11	2.91	190	19	2755	1450	5.4	3.97	9.5	21	0.65
E3B1713	13	3.43	170	17	2465	1450	5.7	4.19	9.5	21	0.65
E3B1515	15	3.96	150	15	2175	1450	5.8	4.26	9.5	21	0.65
E3B1218	18	4.76	120	12	1750	1450	5.6	4.12	9.5	21	0.65
E3B1021	21	5.55	100	10	1450	1450	5.5	4.04	9.5	21	0.65
E3B2511	11	2.91	250	25	3625	1450	7.1	5.22	9.5	21	0.65
E3B2513	13	3.43	250	25	3625	1450	8.4	6.18	9.5	21	0.65
E3B2515	15	3.96	250	25	3625	1450	9.7	7.13	9.5	21	0.65
E3B2118	18	4.76	210	21	3045	1450	9.8	7.21	9.5	21	0.65
E3B2121	21	5.55	210	21	3045	1450	11.5	8.46	9.5	21	0.65



**59****S  
E  
R  
I  
E  
S**

Modello Model Modèle Modell Modelo Modelo	Portata Flow rate Débit Förderstrom Caudal Fluxo		Pressione Pressure Pression Druck Presión Pressão			g/m rpm t/m upm r/m r/m	Potenza Power Puissance Leistung Potencia Poder		Peso Weight Poids Gewicht Peso Peso		
	L/min	gpm	bar	MPa	psi		Hp	kW	Kg	Ibs	
E3C1713	13	3.43	170	17	2465	1750	5.7	4.19	9.5	21	0.65
E3C1515	15	3.96	150	15	2175	1750	5.8	4.26	9.5	21	0.65
E3C1218	18	4.76	120	12	1750	1750	5.6	4.12	9.5	21	0.65
E3C1021	21	5.55	100	10	1450	1750	5.5	4.04	9.5	21	0.65
E3C2513	13	3.43	250	25	3625	1750	8.4	6.18	9.5	21	0.65
E3C2515	15	3.96	250	25	3625	1750	9.7	7.13	9.5	21	0.65
E3C2518	18	4.76	250	25	3625	1750	11.7	8.60	9.5	21	0.65
E3C2521	21	5.55	250	25	3625	1750	13.6	10.00	9.5	21	0.65
E3E2813	13	3.43	275	27.5	4000	3400	9.3	6.84	9.5	21	0.65
E3E2815	15	3.96	275	27.5	4000	3400	10.7	7.87	9.5	21	0.65
E3E2517	17	4.49	250	25	3625	3400	11.0	8.09	9.5	21	0.65
E3E2520	20	5.28	250	25	3625	3400	13.0	9.56	9.5	21	0.65

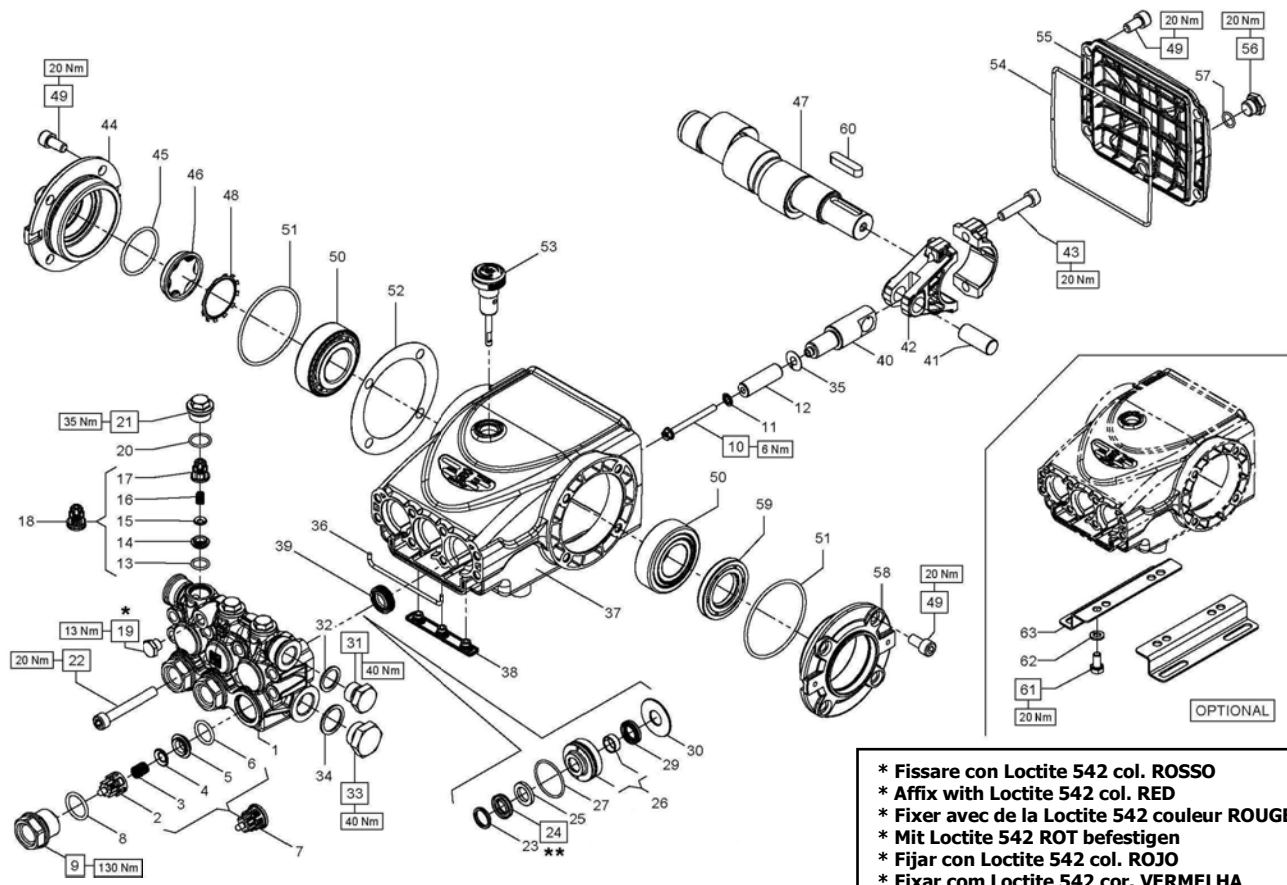

- \* Fissare con Loctite 542 col. ROSSO
- \* Affix with Loctite 542 col. RED
- \* Fixer avec de la Loctite 542 couleur ROUGE
- \* Mit Loctite 542 ROT befestigen
- \* Fijar con Loctite 542 col. ROJO
- \* Fixar com Loctite 542 cor. VERMELHA
  
- \*\* Lubrificare con grasso di vaselina
- \*\* To lubricate with vaseline grease
- \*\* Lubrifier avec gras des vaseline
- \*\* Sich mit fett zum vaselin schmieren
- \*\* Para lubricar con la grasa de vaselina
- \*\* Para lubrificar com a graxa de vaselina

**KIT RICAMBI – SPARE KITS****PIST. Ø 18****PIST. Ø 20****PIST. Ø 22**

**E3A1713 – E3A1515 – E3B1911 – E3B1713**  
**E3B1515 – E3B1218 – E3B1021 – E3C1713**  
**E3C1515 – E3C1218 – E3C1021**

KIT Nr.	KIT 269	KIT 270	KIT 271	KIT 284	KIT 289	KIT 285	KIT 290	KIT 286	KIT 291
<b>Posizioni incluse Positions included</b>	<b>2 – 3 – 4 5 – 6 – 13 14 – 15 – 16 17 – (7) – (18)</b>	<b>8 – 9 20 – 21</b>	<b>39</b>	<b>23 – 24 25 – 27 29</b>	<b>23 – 24 25 – 26 27 – 29 30</b>	<b>23 – 24 25 – 27 29</b>	<b>23 – 24 25 – 26 27 – 29 30</b>	<b>23 – 24 25 – 27 29</b>	<b>23 – 24 25 – 26 27 – 29 30</b>
<b>Nr. Pcs.</b>	<b>3 + 3</b>	<b>3 + 3</b>	<b>3</b>	<b>3</b>	<b>1</b>	<b>3</b>	<b>1</b>	<b>3</b>	<b>1</b>

PISTON Ø 18	PISTON Ø 20	PISTON Ø 22
<b>E3B1911 E3C1713</b>	<b>E3B1713 E3B1515 E3C1515 E3C1218 E3C1021</b>	<b>E3A1713 E3A1515 E3B1218 E3B1021</b>

POS	COD.	DESCRIZIONE – DESCRIPTION - KIT	NR
1	59.1202.41 59.1203.41 59.1204.41	Testata pompa D.18 Testata pompa D.20 Testata pompa D.22	1 1 1
2	36.2025.51	Guida valvola d'aspirazione 269	3
3	94.7676.00	Molla Dm. 9.4x14.8 269	3
4	36.2001.76	Valvola sferica 269	3
5	36.2003.66	Sede valvola d'aspirazione 269	3
6	90.3841.00	OR D. 17.13x2.62 NBR 70 SH 3068 269	3
7	36.7115.01	Gruppo valvola d'aspirazione 269	3
8	90.3847.00	OR D.20.24x2.62 NBR 70 SH 3081 270	3
9	98.2226.00	Tappo M24x1.5x16.7 270	3
10	99.1690.00	Vite M5x55 3	3
11	96.6905.00	Rosetta D.5x11.5x0.4 3	3
12	58.0402.09 59.0400.09 59.0401.09	Pistone D.18x42 Pistone D.20x42 Pistone D.22x42	1 1 1
13	90.3589.00	OR D.12.42x1.78 NBR 70 SH 2050 269	3
14	36.2113.66	Sede valvola di mandata 269	3
15	36.2112.76	Valvola sferica 269	3
16	94.7333.00	Molla Dm.6.2x10.4 269	3
17	36.2111.51	Guida valvola di mandata 269	3
18	36.7193.01	Gruppo valvola di mandata 269	3
19	98.1966.00	Tappo G 1/8"x8 1	1
20	90.3593.00	OR D.15.60x1.78 NBR 70 SH 2062 270	3
21	98.2137.00	Tappo M18x1.5x10 D.23-D.12 270	3
22	99.3175.00	Vite M8x60 UNI 5931 8	8

POS	COD.	DESCRIZIONE – DESCRIPTION - KIT	NR
23	66.1007.51 66.1009.51 63.1010.51	Anello di testa D.20 285-290 Anello di testa D.22 286-291 Anello di testa D.18 284-289	3 3 3
24	90.2691.00 90.2716.00 90.2653.50	An. ten.alt. D.20x30x6/3.7 HP 285-290 An. ten.alt. D.22x32x6/3.7 HP 286-291 An. ten.alt. D.18x28x46/3.7 HP 284-289	3 3 3
25	90.5111.50 90.5134.00 90.5148.50	Anello antiest. D.18x28x2 284-289 Anello antiest. D.20x30x2 285-290 Anello antiest. D.22x32x2 286-291	3 3 3
26	59.6060.01 59.6061.01 59.6062.01	Gr. supp. guarn./bussola D.18 289 Gr. supp. guarn./bussola D.20 290 Gr. supp. guarn./bussola D.22 291	3 3 3
27	90.3612.00	OR D.31.47x1.78 NBR 70 SH. 2125 282-283-284-285-286-287-288-289-290-291	3
29	90.2690.00 90.2715.00 90.2650.00	Anello ten. alt. D.20x28x6.5 LP 285-290 Anello ten. alt. D.22x30x6.5 LP 286-291 Anello ten. alt. D.18x24x5 LP 284-289	3 3 3
30	59.2107.70 59.2108.70 59.2109.70	Anello per tenuta D.18 289 Anello per tenuta D.20 290 Anello per tenuta D.22 291	3 3 3
31	98.2100.00	Tappo G 3/8"x13 1	1
32	96.7380.00	Rosetta D.17.5x23x1.5 1	1
33	98.2176.00	Tappo G 1/2"x10 1	1
34	96.7514.00	Rosetta D.21.5x27x1.5 1	1
35	96.6990.00	Rosetta D.7.5x23x0.5 3	3
36	59.2110.82	Guarnizione spugna D.3x103 1	1
37	59.0100.22	Carter pompa 1	1
38	58.2104.51	Protezione 1	1
39	90.1565.50	Anello rad. D.15x24x5/7 271	3
40	59.050066	Guida pistone 3	3
41	97.7399.00	Spinotto D.14x34 3	3

POS	COD.	DESCRIZIONE – DESCRIPTION - KIT	NR
42	59.0300.01	Biella completa 3	3
43	99.3099.00	Vite serraggio biella M8x35 6	6
44	47.1512.22	Coperchio laterale lato spia 1	1
45	90.3877.00	OR D.39.34x2.62 NBR 70 SH. 3156 1	1
46	70.2118.01	Spia livello olio 1	1
47	59.0201.35 59.0202.35 59.0203.35	Albero - E3A1515-E3B1021-E3C1021 1 Albero - E3A1713-E3B1218-E3B1515-E3C1218 1 Albero - E3B1911-E3C1713-E3B1713-E3C1515 1	1 1 1
48	90.0756.00	Anello seeger D.45 1	1
49	99.3039.00	Vite M8x16 UNI 5931 12	12
50	91.8375.00	Cuscinetto a rulli 30x62x21.25 2	2
51	90.3913.00	OR D.67.95x2.62 NBR 70 SH. 3628 2	2
52	97.5680.00 97.5978.00	Spessore D.74.5x104x0.3 1 Spessore D.74.5x104x0.1 1	1 1
53	98.2105.00	Asta livello olio G 3/8"x51 D.7 1	1
54	90.3922.00	OR D.133.02x2.62 NBR 70 SH. 3525 1	1
55	59.1600.22	Coperchio posteriore carter 1	1
56	98.2042.50	Tappo G 1/4"x9 TE17 – Zinc. 1	1
57	90.3585.00	OR D.10.82x1.78 NBR 70 SH. 2043 1	1
58	47.1510.22	Coperchio laterale lato PTO 1	1
59	90.1648.00	Anello rad. D.30x55x7 1	1
60	91.4892.00	Linguetta 8x7x35 1	1
61	99.3037.00	Vite M8x16 UNI 5739 4	4
62	96.7016.00	Rosetta D. 8.4 UNI 1751 4	4
63	50.2000.74	Piedino pompa 2	2



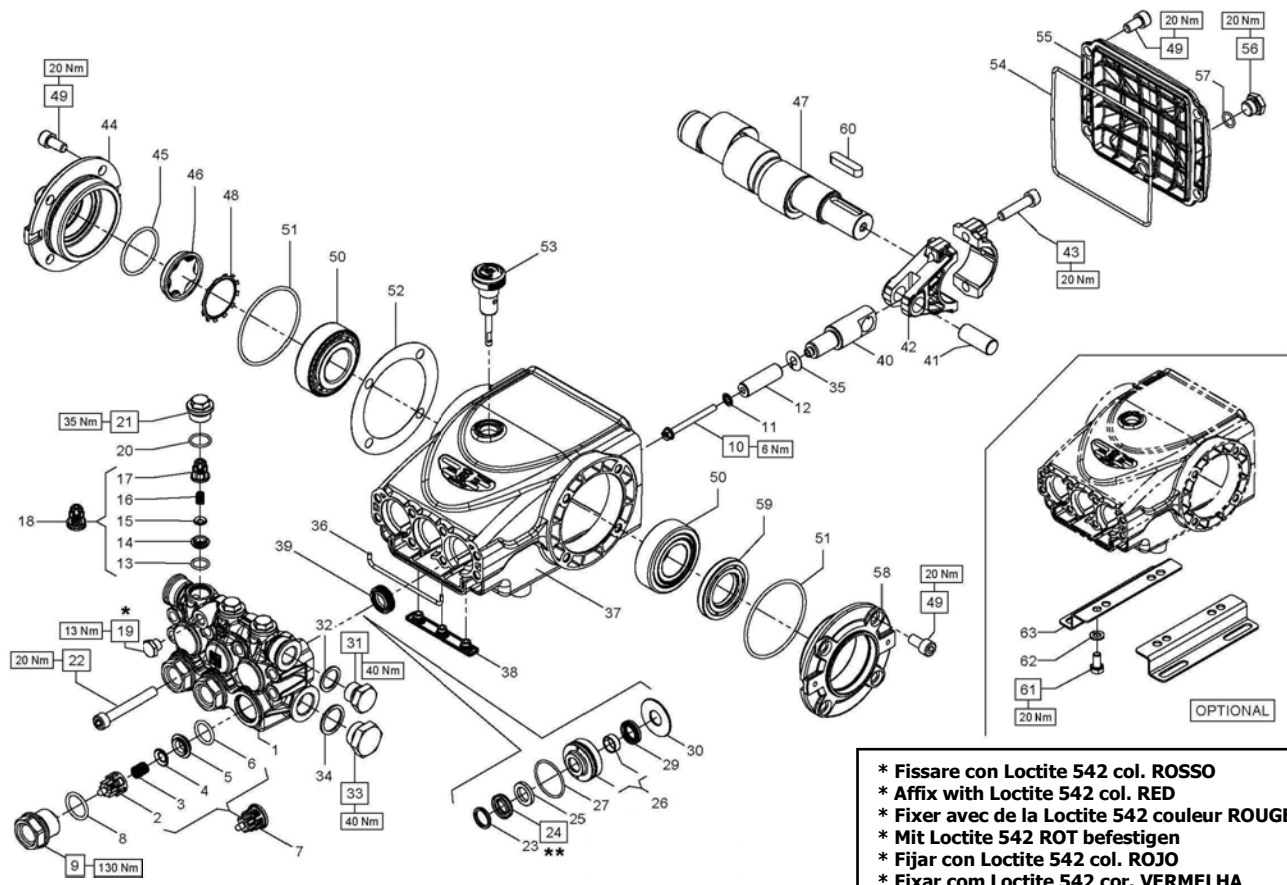

**\* Fissare con Loctite 542 col. ROSSO**  
**\* Affix with Loctite 542 col. RED**  
**\* Fixer avec de la Loctite 542 couleur ROUGE**  
**\* Mit Loctite 542 ROT befestigen**  
**\* Fijar con Loctite 542 col. ROJO**  
**\* Fixar com Loctite 542 cor. VERMELHA**

**\*\* Lubrificare con grasso di vaselina**  
**\*\* To lubricate with vaseline grease**  
**\*\* Lubrifier avec gras des vaseline**  
**\*\* Sich mit fett zum vaselin schmieren**  
**\*\* Para lubricar con la grasa de vaselina**  
**\*\* Para lubrificar com a graxa de vaselina**

**KIT RICAMBI – SPARE KITS****PIST. Ø 13****PIST. Ø 15****PIST. Ø 18****PIST. Ø 20****PIST. Ø 22**

**E3A2113 – E3A2115 – E3B2511 – E3B2513  
E3B2515 – E3B2118 – E3B2121 – E3C2513  
E3C2515 – E3C2518 – E3C2521 – E3E2813  
E3E2815 – E3E2517 – E3E2520**

KIT Nr.	KIT 269	KIT 292	KIT 271	KIT 282	KIT 287	KIT 283	KIT 288	KIT 284	KIT 289	KIT 285	KIT 290	KIT 286	KIT 291
Posizioni include Positions included	2 – 3 – 4 5 – 6 – 13 14 – 15 – 16 17 - (7) - (18)	8 – 9 20 - 21	39	23 – 24 25 – 27 29	23 – 24 25 – 26 27 – 29 30	23 – 24 25 – 27 29	23 – 24 25 – 26 27 – 29 30	23 – 24 25 – 27 29	23 – 24 25 – 26 27 – 29 30	23 – 24 25 – 27 29	23 – 24 25 – 26 27 – 29 30	23 – 24 25 – 27 29	23 – 24 25 – 26 27 – 29 30
Nr. Pcs.	3 + 3	3 + 3	3	3	1	3	3	1	3	1	3	1	3

PISTON Ø 13	PISTON Ø 15	PISTON Ø 18	PISTON Ø 20	PISTON Ø 22
E3E2813 E3E2815	E3E2517 E3E2520	E3C2511 E3C2513	E3B2513 E3B2515 E3C2515 E3C2518 E3C2521	E3A2113 E3A2115 E3B2118 E3B2121

POS	COD.	DESCRIZIONE – DESCRIPTION - KIT	NR
1	59.1210.41 59.1211.41 59.1212.41 59.1213.41 59.1214.41	Testata pompa D.13 - NICKEL Testata pompa D.15 - NICKEL Testata pompa D.18 - NICKEL Testata pompa D.20 - NICKEL Testata pompa D.22 - NICKEL	1 1 1 1 1
2	36.2025.51	Guida valvola d'aspirazione 269	3
3	94.7676.00	Molla Dm. 9.4x14.8	269
4	36.2001.76	Valvola sferica	269
5	36.2003.66	Sede valvola d'aspirazione	269
6	90.3841.00	OR D. 17.13x2.62 NBR 70 SH 3068269	3
7	36.7115.01	Gruppo valvola d'aspirazione	269
8	90.3847.00	OR D.20.24x2.62 NBR 70 SH 3081 292	3
9	98.2225.00	Tappo M24x1.5x16.7 - NICKEL	292
10	99.1690.00	Vite M5x55	3
11	96.6905.00	Rosetta D.5x11.5x0.4	3
12	58.0400.09 58.0401.09 58.0402.09 59.0400.09 59.0401.09	Pistone D.13x42 Pistone D.15x42 Pistone D.18x42 Pistone D.20x42 Pistone D.22x42	1 1 1 1 1
13	90.3589.00	OR D.12.42x1.78 NBR 70 SH 2050 269	3
14	36.2113.66	Sede valvola di mandata	269
15	36.2112.76	Valvola sferica	269
16	94.7333.00	Molla Dm.6.2x10.4	269
17	36.2111.51	Guida valvola di mandata	269
18	36.7193.01	Gruppo valvola di mandata	269
19	98.1967.00	Tappo G 1/8"x8 - NICKEL	1
20	90.3593.00	OR D.15.60x1.78 NBR 70 SH 2062 292	3
21	98.2137.50	Tappo M18x1.5x10 D.23-D.12 - NK 292	3

POS	COD.	DESCRIZIONE – DESCRIPTION - KIT	NR
22	99.3175.00	Vite M8x60 UNI 5931	8
23	66.1007.51 66.1009.51 63.1010.51 63.1011.51 44.1002.51	Anello di testa D.20 Anello di testa D.22 Anello di testa D.15 Anello di testa D.18 Anello di testa D.13	285-290 286-291 283-288 284-289 282-287
24	90.2691.00 90.2716.00 90.2611.00 90.2653.50 90.2602.00	An. ten.alt. D.20x30x6/3.7 HP An. ten.alt. D.22x32x6/3.7 HP An. ten.alt. D.15x24x5.4/3.4 HP An. ten.alt. D.18x28x4/3.7 HP An. ten.alt. D.13x21x4 HP	285-290 286-291 283-288 284-289 282-287
25	90.5076.50 90.5089.90 90.5111.50 90.5134.00 90.5148.50	Anello antiest. D.13x21x4 Anello antiest. D.15x24x2 Anello antiest. D.18x28x2 Anello antiest. D.20x30x2 Anello antiest. D.22x32x2	282-287 283-288 284-289 285-290 286-291
26	59.6058.01 59.6059.01 59.6060.01 59.6061.01 59.6062.01	Gr. suup. guarn./boccola D.13 Gr. suup. guarn./boccola D.15 Gr. suup. guarn./boccola D.18 Gr. suup. guarn./boccola D.20 Gr. suup. guarn./boccola D.22	287 288 289 290 291
27	90.3612.00	OR D.31.47x1.78 NBR 70 SH. 2125 282-283-284-285-286-287-288-289-290-291	3
29	90.2690.00 90.2715.00 90.2608.00 90.2650.00 90.2601.00	Anello ten. alt. D.20x28x6.5 LP Anello ten. alt. D.22x30x6.5 LP Anello ten. alt. D.15x22x5 LP Anello ten. alt. D.18x24x5 LP Anello ten. alt. D.13x20x5 LP	285-290 286-291 283-288 284-289 282-287
30	59.2105.70 59.2106.70 59.2107.70 59.2108.70 59.2109.70	Anello per tenuta D.13 Anello per tenuta D.15 Anello per tenuta D.18 Anello per tenuta D.20 Anello per tenuta D.22	287 288 289 290 291
31	98.2099.00	Tappo G 3/8"x13 - NICKEL	1
32	96.7380.00	Rosetta D.17.5x23x1.5	1
33	98.2179.00	Tappo G 1/2"x10 - NICKEL	1
34	96.7514.00	Rosetta D.21.5x27x1.5	1
35	96.6990.00	Rosetta D.7.5x23x0.5	3

POS	COD.	DESCRIZIONE – DESCRIPTION - KIT	NR
36	59.2110.82	Guarnizione spugna D.3x103	1
37	59.0100.22	Carter pompa	1
38	58.2104.51	Protezione	1
39	90.1565.50	Anello rad. D.15x24x5/7	271
40	59.050066	Guida pistone	3
41	97.7399.00	Spinotto D.14x34	3
42	59.0300.01	Biella completa	3
43	99.3099.00	Vite serraggio biella M8x35	6
44	47.1512.22	Coperchio laterale lato spia	1
45	90.3877.00	OR D.39.34x2.62 NBR 70 SH. 3156	1
46	70.2118.01	Spia livello olio	1
47	59.0201.35 59.0202.35 59.0203.35	Albero – E3A2115-E3B2121-E3C2521-E3E2815 Albero – E3A2113-E3B2118-E3B2515-E3C2518 E3E2520 Albero – E3B2511-E3B2513-E3C2513-E3C2515 E3E2813-E3E2517	1 1 1
48	90.0756.00	Anello seeger D.45	1
49	99.3039.00	Vite M8x16 UNI 5931	12
50	91.8375.00	Cuscinetto a rulli 30x62x21.25	2
51	90.3913.00	OR D.67.95x2.62 NBR 70 SH. 3628	2
52	97.5680.00 97.5978.00	Spessore D.74.5x104x0.3 Spessore D.74.5x104x0.1	1 1
53	98.2105.00	Asta livello olio G 3/8"x51 D.7	1
54	90.3922.00	OR D.133.02x2.62 NBR 70 SH. 3525	1
55	59.1600.22	Coperchio posteriore carter	1
56	98.2042.50	Tappo G 1/4"x9 TE17 – ZINC.	1
57	90.3585.00	OR D.10.82x1.78 NBR 70 SH. 2043	1
58	47.1510.22	Coperchio laterale lato PTO	1
59	90.1648.00	Anello rad. D.30x55x7	1
60	91.4892.00	Linguetta 8x7x35	1
61	99.3037.00	Vite M8x16 UNI 5739	4
62	96.7016.00	Rosetta D. 8.4 UNI 1751	4
63	50.2000.74	Piedino pompa	2

\* Fissare con Loctite 542 col. ROSSO  
 \* Affix with Loctite 542 col. RED  
 \* Fixer avec de la Loctite 542 couleur ROUGE  
 \* Mit Loctite 542 ROT befestigen  
 \* Fijar con Loctite 542 col. ROJO  
 \* Fixar com Loctite 542 cor. VERMELHA

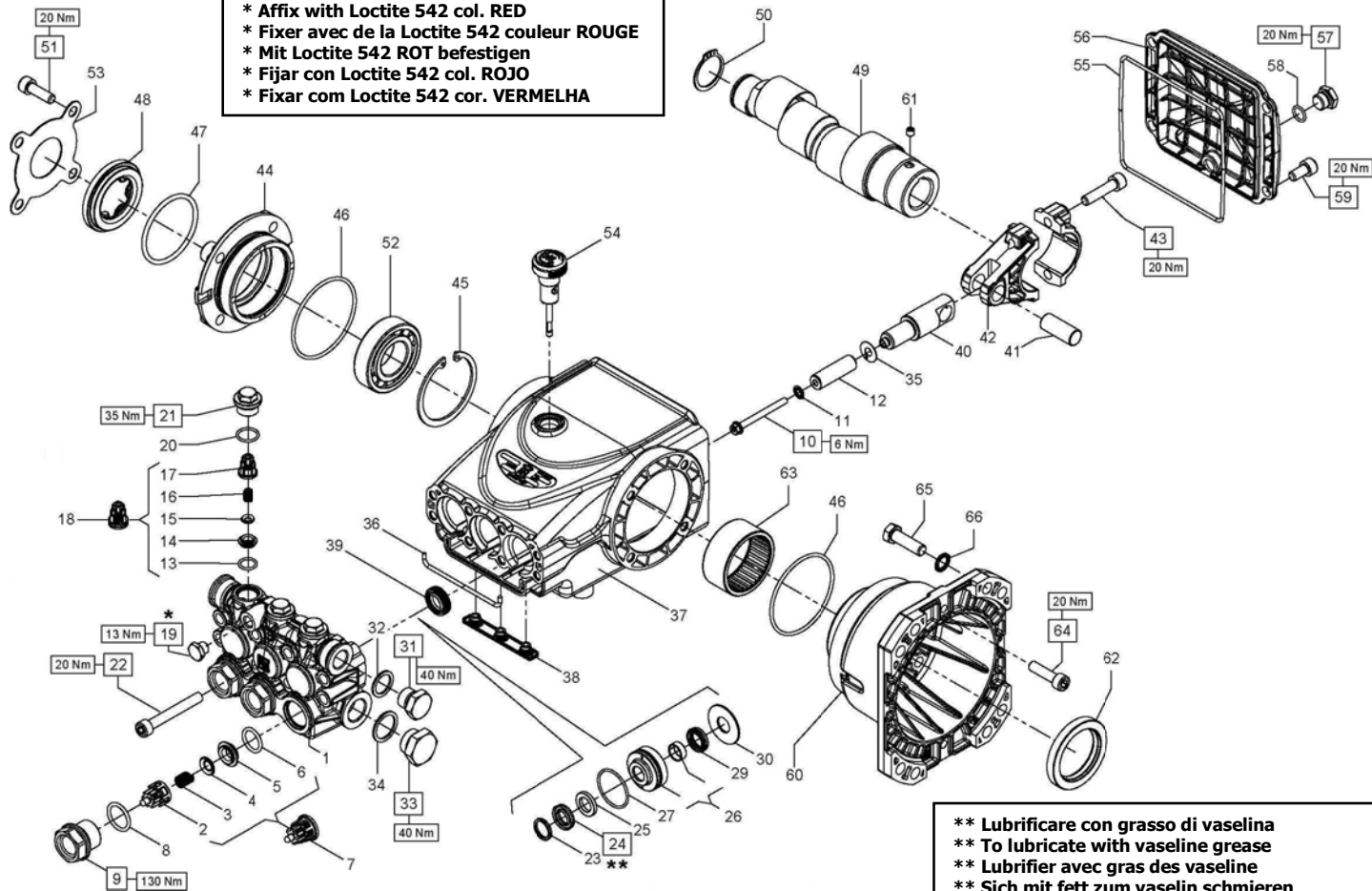

\*\* Lubrificare con grasso di vaselina  
 \*\* To lubricate with vaseline grease  
 \*\* Lubrifier avec gras des vaseline  
 \*\* Sich mit fett zum vaselin schmieren  
 \*\* Para lubricar con la grasa de vaselina  
 \*\* Para lubrificar com a graxa de vaselina

**KIT RICAMBI – SPARE KITS****PIST. Ø 13****PIST. Ø 15****E3E2813 – E3E2815  
E3E2517 – E3E2520**

KIT Nr.	KIT 269	KIT 292	KIT 271	KIT 282	KIT 287	KIT 283	KIT 288
<b>Posizioni include</b> <b>Positions included</b>	2 – 3 – 4 5 – 6 - 13 14 – 15 – 16 17 – (7) - (18)	8 – 9 20 - 21	39	23 – 24 25 – 27 29	23 – 24 25 – 26 27 – 29 30	23 – 24 25 – 27 29	23 – 24 25 – 26 27 – 29 30
<b>Nr. Pcs.</b>	<b>3 + 3</b>	<b>3 + 3</b>	<b>3</b>	<b>3</b>	<b>1</b>	<b>3</b>	<b>1</b>

**PISTON Ø 13****PISTON Ø 15****E3E2813 - E3E2815****E3E2517 - E3E2520**

POS	COD.	DESCRIZIONE – DESCRIPTION - KIT	NR
1	59.1210.41	Testata pompa D.13 - NICKEL	1
	59.1211.41	Testata pompa D.15 - NICKEL	1
2	36.2025.51	Guida valvola d'aspirazione 269	3
3	94.7676.00	Molla Dm. 9.4x14.8 269	3
4	36.2001.76	Valvola sferica 269	3
5	36.2003.66	Sede valvola d'aspirazione 269	3
6	90.3841.00	OR D. 17.13x2.62 NBR 70 SH 3068 269	3
7	36.7115.01	Gruppo valvola d'aspirazione 269	3
8	90.3847.00	OR D.20.24x2.62 NBR 70 SH 3081 292	3
9	98.2225.00	Tappo M24x1.5x16.7 – NICKEL 292	3
10	99.1690.00	Vite M5x55	3
11	96.6905.00	Rosetta D.5x11.5x0.4	3
12	58.0400.09	Pistone D.13x42	1
	58.0401.09	Pistone D.15x42	1
13	90.3589.00	OR D.12.42x1.78 NBR 70 SH 2050 269	3
14	36.2113.66	Sede valvola di mandata 269	3
15	36.2112.76	Valvola sferica 269	3
16	94.7333.00	Molla Dm.6.2x10.4 269	3
17	36.2111.51	Guida valvola di mandata 269	3
18	36.7193.01	Gruppo valvola di mandata 269	3
19	98.1967.00	Tappo G 1/8"x8 - NICKEL	1
20	90.3593.00	OR D.15.60x1.78 NBR 70 SH 2062 292	3
21	98.2137.50	Tappo M18x1.5x10 D.23-D.12 – NK 292	3
22	99.3175.00	Vite M8x60 UNI 5931	8
23	63.1010.51	Anello di testa D.15 283-288	3
	44.1002.51	Anello di testa D.13 282-287	3

POS	COD.	DESCRIZIONE – DESCRIPTION - KIT	NR
24	90.2611.00	An. ten.alt. D.15x24x5.4/3.4 HP 283-288	3
	90.2602.00	An. ten.alt. D.13x21x4 HP 282-287	3
25	90.5076.50	Anello antiest. D.13x21x4 282-287	3
	90.5089.90	Anello antiest. D.15x24x2 283-288	3
26	59.6058.01	Gr. supp. guarn./bussola D.13 287	3
	59.6059.01	Gr. supp. guarn./bussola D.15 288	3
27	90.3612.00	OR D.31.47x1.78 NBR 70 SH. 2125 282-283-284-285-286-287-288-289-290-291	3
29	90.2608.00	Anello ten. alt. D.15x22x5 LP 283-288	3
	90.2601.00	Anello ten. alt. D.13x20x5 LP 282-287	3
30	59.2105.70	Anello per tenuta D.13 287	3
	59.2106.70	Anello per tenuta D.15 288	3
31	98.2099.00	Tappo G 3/8"x13 - NICKEL	1
32	96.7380.00	Rosetta D.17.5x23x1.5	1
33	98.2179.00	Tappo G 1/2"x10 - NICKEL	1
34	96.7514.00	Rosetta D.21.5x27x1.5	1
35	96.6990.00	Rosetta D.7.5x23x0.5	3
36	59.2110.82	Guarnizione spugna D.3x103	1
37	59.0100.22	Carter pompa	1
38	58.2104.51	Protezione	1
39	90.1565.50	Anello rad. D.15x24x5/7 271	3
40	59.0500.66	Guida pistone	3
41	97.7399.00	Spinotto D.14x34	3
42	59.0300.01	Biella completa	3
43	99.3099.00	Vite serraggio biella M8x35	6
44	47.1500.22	Coperchio laterale lato spia	1
45	90.0850.00	Anello seeger D.62	1
46	90.3913.00	OR D.67.95x2.62 NBR 70 SH. 3628	2
47	90.4097.00	OR D.55.56x3.53 NBR 70 SH. 159	1

POS	COD.	DESCRIZIONE – DESCRIPTION - KIT	NR
48	44.2118.01	Distanziale con indicatore	1
49	59.0204.65	Albero – E3E2815	1
	59.0205.65	Albero – E3E2520	1
	59.0206.65	Albero – E3E2517-E3E2813	1
50	90.066700	Anello seeger D.30	1
51	99.3069.00	Vite M8x25 UNI 5931	4
52	91.8376.00	Cuscinetto a rulli	1
53	66.1502.74	Coperchio anteriore carter	1
54	98.2105.00	Asta livello olio G 3/8"x51 D.7	1
55	90.3922.00	OR D.133.02x2362 NBR 70 SH. 3525	1
56	59.1600.22	Coperchio posteriore carter	1
57	98.2042.50	Tappo G 1/4"x9 TE17 – Zinc.	1
58	90.3585.00	OR D.10.82x1.78 NBR 70 SH. 2043	1
59	99.3039.00	Vite M8x16 UNI 5931	4
60	10.0801.22	Flangia motore a scoppio C1"	1
61	99.1790.00	Vite M6x6 UNI 5929	1
62	90.1690.00	Anello rad. D.45x62x8	1
63	91.8585.00	Boccola a rullini D.50x58x25	1
64	90.3084.00	Vite M8x30 UNI 5931	4
65	99.3346.00	Vite 3/8"-16x1-1/4"	4
66	96.7104.00	Rosetta D.10.5x16x1	4



# VH VERSION

VERSIONE CON VALVOLA DI REGOLAZIONE AUT. - VERSION WITH BUILT-IN AUT. UNLOADER  
 VERSION AVEC RÉGULATEUR AUT. DE PRESSION INCORPORÉ  
 AUSFÜHRUNG MIT EINGEBAUTEM AUT. DRUCKREGULIERVENTIL  
 VERSIÓN CON REGULADOR AUT. DE PRESIÓN INCORPORADO - VERSÃO COM VÁLVULA DO REGULAMENTO AUT.

## OPTIONALS

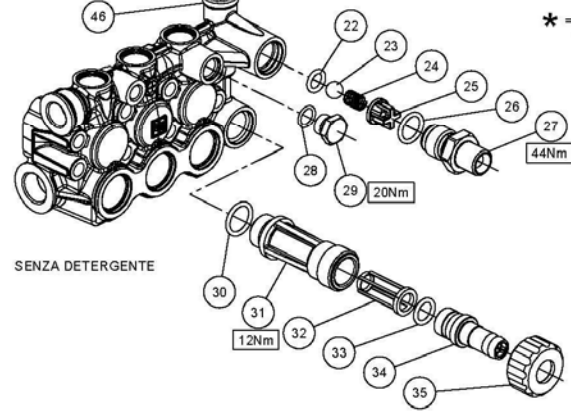
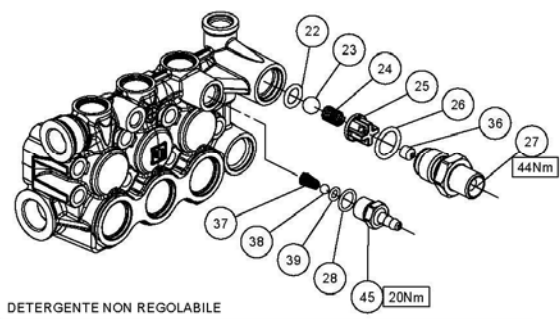
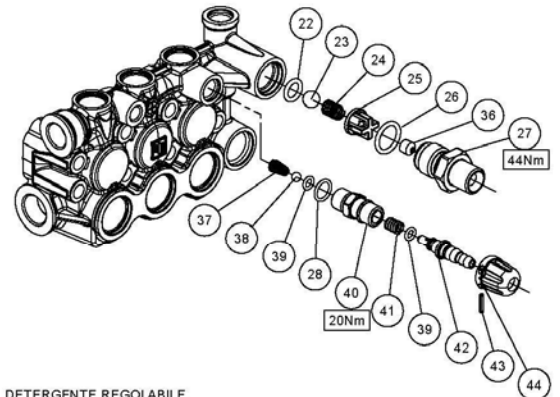
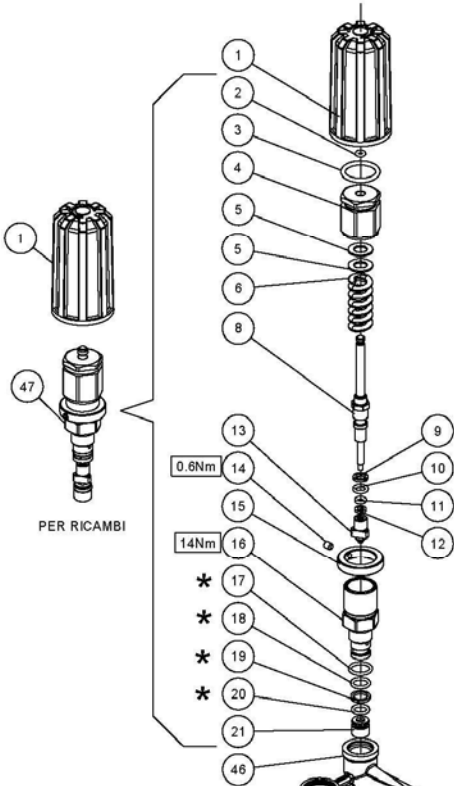

\* = Se necessario prima del montaggio ingrassare.  
 - Usare grasso di vaselina per pompe -

# VH VERSION

**VERSIONE CON VALVOLA DI REGOLAZIONE AUT. – VERSION WITH BUILT-IN AUT. UNLOADER  
VERSION AVEC RÉGULATEUR AUT. DE PRESSION INCORPORÉ  
AUSFÜHRUNG MIT EINGEBAUTEM AUT. DRUCKREGULIERVENTIL  
VERSIÓN CON REGULADOR AUT. DE PRESIÓN INCORPORADO - VERSÃO COM VÁLVULA DO REGULAMENTO AUT.**

POS	COD.	DESCRIZIONE – DESCRIPTION - KIT	NR	POS	COD.	DESCRIZIONE – DESCRIPTION - KIT	NR
1	36.3485.51	Pomolo di regolazione	1	36	10.0795.66 10.0798.66	Ugello per iniettore Ø 2 Ugello per iniettore Ø 2.2	1
2	90.3566.00	OR D.2.90X1.78 NBR 70 SH. 2012	1	37	94.8217.00	Molla conica Ø 4.3/7.3x11 279-280	1
3	90.3845.00	OR D.18.72X2.62 NBR 70 SH. 3075	1	38	97.4782.00	Sfera Ø 7/32" 279-280	1
4	36.3481.70	Registro di pressione	1	39	90.3573.00	OR Ø 5.28x1.78 NBR 70 Sh. 2021 279-280	2
5	36.3486.51	Rondella di scorrimento	2	40	36.3482.70	Sede valvola detergente 279	1
6	94.7395.00	Molla D.11.3x34.5	1	41	94.7334.00	Molla Ø 6.4x12.5 279	1
8	N.A.	Pistoncino di comando	1	42	36.3342.70	Otturatore con portagomma 279	1
9	N.A.	Anello antiest. D.6.1x9x1.5	1	43	97.6615.00	Spina elastica Ø 2x12 UNI 6873 279	1
10	N.A.	OR D.6.07x1.78 NBR 70 Sh. 2025	1	44	36.3484.51	Pomolo detergente rosso 279	1
11	N.A.	OR D.3.69x1.78 NBR 70 Sh. 2015	1	45	36.3492.70	Portagomma 280	1
12	N.A.	Anello antiest. D.4x7x1.5	1	46	59.1206.41 59.1207.41 59.1208.41 59.1209.41	Testata pompa con valv. integr. D.15 Testata pompa con valv. integr. D.18 Testata pompa con valv. integr. D.20 Testata pompa con valv. integr. D.22	1
13	N.A.	Otturatore	1	47	36.6054.01	Frutto valvola con sede 278	1
14	99.1267.00	Vite M4x5 UNI 5929	1	<b>OPTIONALS</b>			
15	36.3477.70	Ghiera di pressione massima	1	30	90.3841.00	OR Ø 17.13x2.62 NBR 70 Sh. 3068	1
16	N.A.	Boccola di guida	1	31	36.3182.51	Nipplo aspirazione G 3/4"	1
17	90.3587.00	OR D.11.11x1.78 NBR 70 SH. 114	1	32	92.8925.00	Filtro Ø 12x35	1
18	90.3581.00	OR D.8.73x1.78 NBR 70 SH. 108	1	33	90.3828.00	OR Ø 12.37x2.62 NBR 70 Sh. 3050	1
19	90.5038.00	Anello antiest. D.9x12x1.5	1	34	36.2569.51	Portagomma aspirazione	1
20	90.3578.00	OR D.7.66x1.78 NBR 70 SH. 2031	1	35	92.9828.00	Ghiera G 3/4" – Ø 15	1
21	36.3483.66	Sede	1	<b>N.A. : NOT AVAILABLE – PARTICOLARE NON FORNITO</b>			
22	90.3823.00	OR D.9.92x2.62 NBR 70 SH. 112 278	1	<b>KIT RICAMBI – SPARE KITS</b>			
23	97.4838.00	Sfera Ø 13/32" 278	1	<b>KIT NR.      KIT 278      KIT 279      KIT 280</b>			
24	94.7355.00	Molla Ø 8.5x12 278	1	<b>Posizioni include      22 – 23      28 – 37      28 – 37</b>			
25	36.3104.51	Guida valvola 278	1	<b>Positions      24 – 25      38 – 39      38 – 39</b>			
26	90.3839.00	OR Ø 15.88x2.62 NBR 70 Sh. 121 278	1	<b>included      26 - 47      40 – 41      40 – 41</b>			
27	36.3490.70	Nipplo 3/8" NPT – F – Ø3	1	<b>42 – 43      44</b>			
	36.3489.70	Nipplo G 3/8" – F – Ø3		<b>Nr. Pcs.      -      -      -</b>			
	36.3488.70	Nipplo M22x1.5 – Ø3					
	36.3487.70	Nipplo 3/8" NPT – M – Ø3					
	36.3479.70	Nipplo G 3/8" – M – Ø3					
28	90.3585.00	OR Ø 10.82x1.78 NBR 70 Sh. 2043 279-280	1				
29	98.2041.00	Tappo G 1/4"x9	1				

**DIMENSIONI D'INGOMBRO – OVERALL DIMENSIONS – DIMENSIONS D'ENCOMBREMENT  
RAUMBEDARF – DIMENSIONES TOTALES – DIMENSÕES**

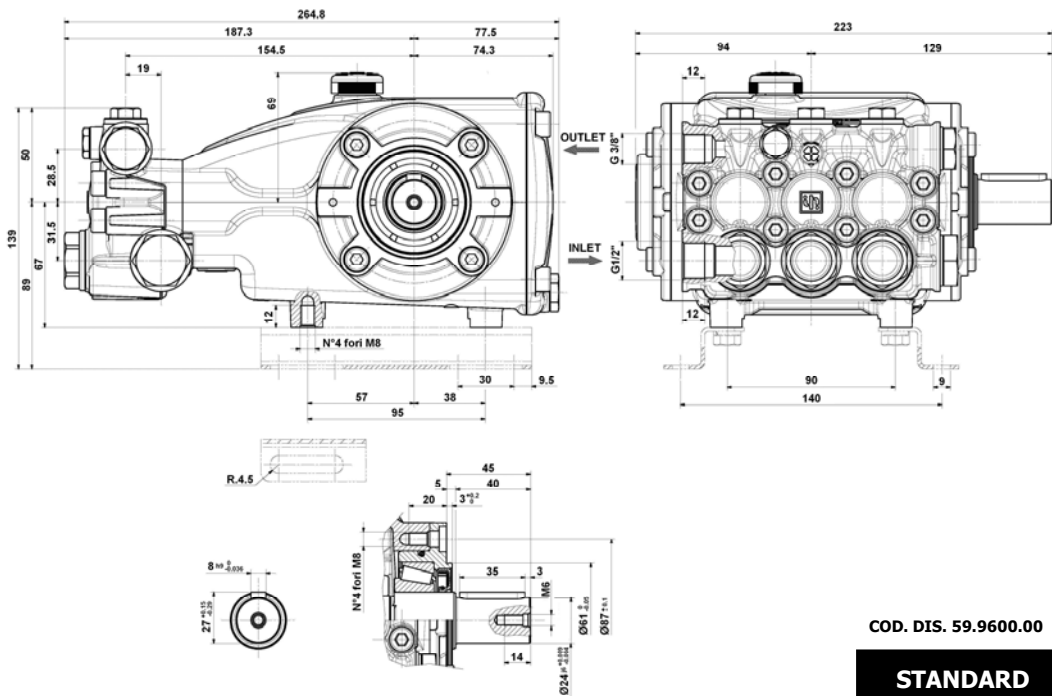

COD. DIS. 59.9600.00

**STANDARD**

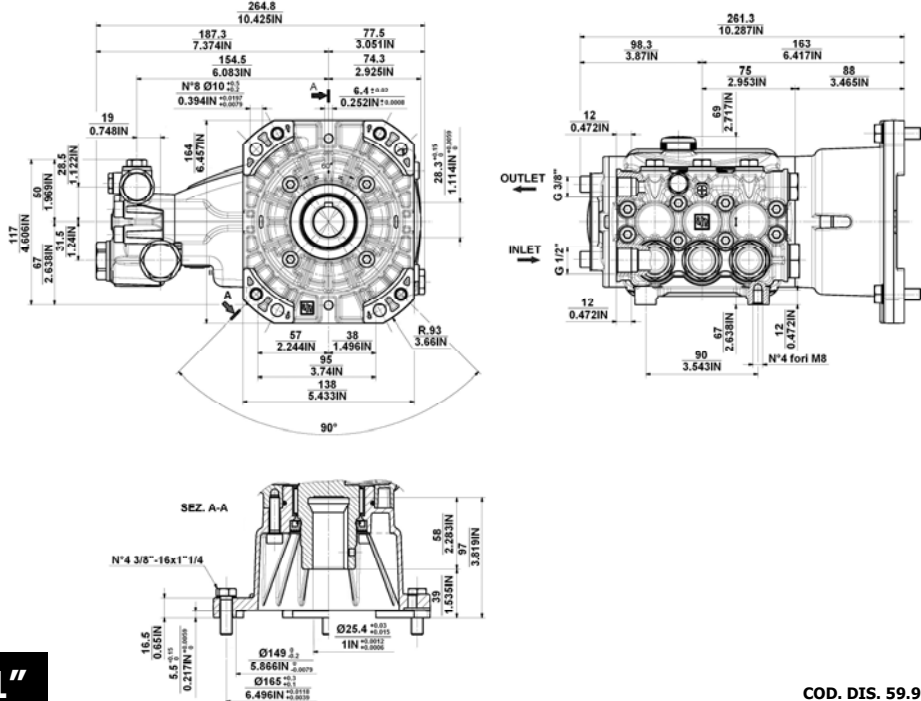

**C1"**

COD. DIS. 59.9602.00

**DIMENSIONI D'INGOMBRO – OVERALL DIMENSIONS – DIMENSIONS D'ENCOMBREMENT  
RAUMBEDARF – DIMENSIONES TOTALES – DIMENSÕES**

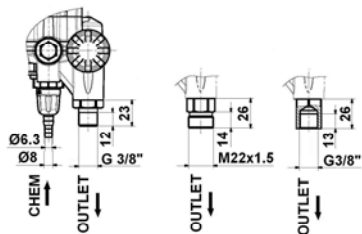
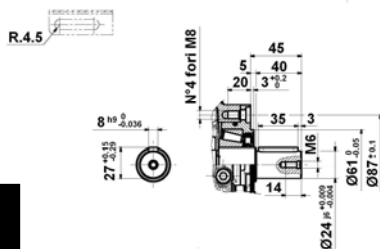
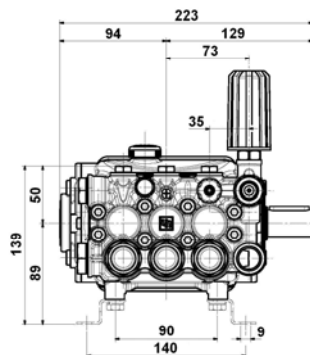
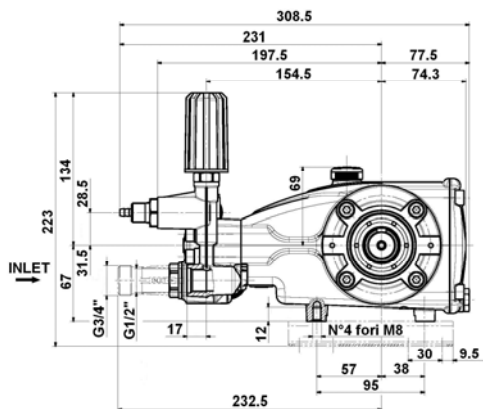

**STANDARD  
VH VALVE**

**COD. DIS. 59.9601.00**

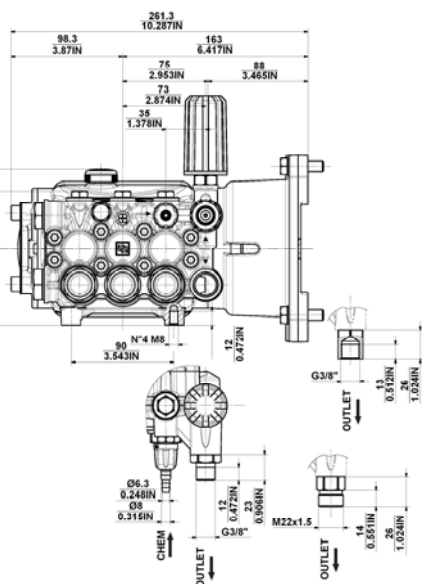
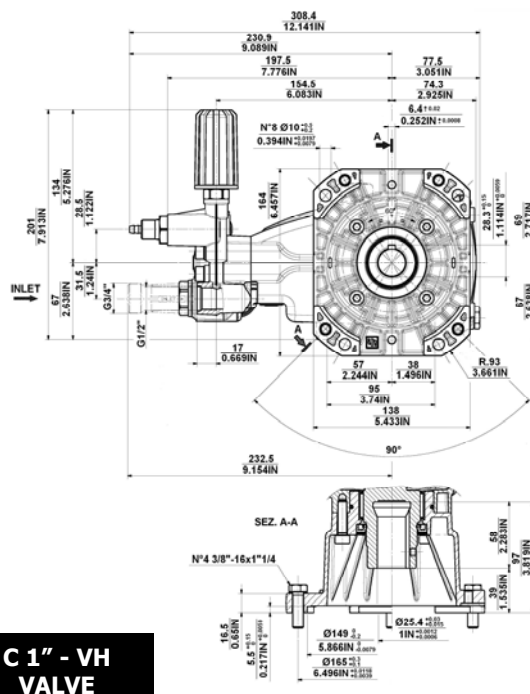

**C 11" - VH  
VALVE**

**COD. DIS. 59.9603.00**



## 1 - CAMBIO OLIO

- 1.1 – Il cambio dell'olio va eseguito con pompa a temperatura di lavoro.
- 1.2 – Posizionare un recipiente sotto il tappo di scarico olio (3).
- 1.3 – Rimuovere il tappo con asta (1) e successivamente il tappo di scarico (3).
- 1.4 – Attendere fino a quando tutto l'olio è uscito, quindi riavvitare il tappo di scarico (3) con la coppia torcente indicata su disegno esploso.
- 1.5 – Riempire con olio nuovo fino al raggiungimento della mezzeria del tappo spia livello olio (2) e riavvitare il tappo con asta (1).

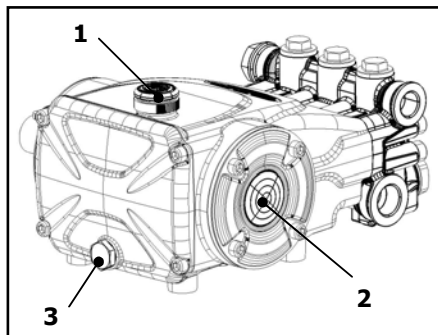

**Per il tipo di olio da utilizzare fare riferimento a quanto indicato sul libretto generico.**



**ATTENZIONE: L'olio esausto deve essere raccolto in recipienti e smaltito negli appositi centri in accordo alla normativa vigente. Non deve essere assolutamente disperso nell'ambiente.**

## 1 – OIL CHANGING

- 1.1 – Oil changing must be done with the pump at operating temperature.
- 1.2 – Put a container under the oil drain plug (3).
- 1.3 – Remove the oil dipstick (1) and then the drain plug (3).
- 1.4 – Wait until all the oil has drained out, then screw the drain plug (3) and tighten at the torque shown in the exploded diagram.
- 1.5 – Fill with new oil until the middle of the oil level indicator (2) is reached, screw by hand the oil dipstick (1).

**Refer to the generic booklet for the type of oil to use.**



**WARNING: The exhaust oil must be collected in receptacles and disposed of at authorised centres as specified by law. It must not be thrown away in the environment.**

## 1 - CHANGEMENT DE L'HUILE

- 1.1 – Le changement de l'huile doit être exécuté avec la pompe à température d'exercice.
- 1.2 – Placer un récipient sous le bouchon de vidange de l'huile (3).
- 1.3 – Enlever le bouchon-jauge (1), puis enlever le bouchon de vidange (3).
- 1.4 – Attendre que toute l'huile soit sortie, puis revisser le bouchon de vidange (3) avec le couple de torsion qui est indiqué sur le dessin éclaté.
- 1.5 – Remplir avec de l'huile neuve jusqu'à la ligne médiane du bouchon indicateur du niveau d'huile (2), et revisser le bouchon-jauge (1).

**Pour le type d'huile à utiliser, se référer à ce qui est indiqué sur la notice générale.**



**ATTENTION : L'huile usée doit être recueillie dans des récipients et éliminée dans les centres prévus à cet effet, conformément à la réglementation en vigueur. Il ne faut absolument pas la jeter dans l'environnement.**