



P.A. – S.p.A. – EQUIPAGGIAMENTI TECNICI DEL LAVAGGIO

VIA MILANO, 13 – CASELLA POSTALE 115 – 42048 RUBIERA (REGGIO EMILIA) – ITALY
 Tel. +39 0522 623611 – Fax. +39 0522 629600 – R.E.A. RE 156319 – R.I. RE11535 – Mecc. RE 013446
 C.F. e P. IVA 01035950359 – Cap. Soc. i.v. € 750.000,00 – Codice Identificativo C.E.E. IT 01035950359
 ART. 2497 – BIS C.C. DIREZIONE E COORDINAMENTO BENETTI srl R.I. TRIB. DI RE 01480690351
 Web: <http://www.pa-etf.it> – E-mail: info@pa-etf.it



VNR-OHD VNR-IHD - Check Valve

Technical manual: **E 280**

Flow regulating valve.

Allows a one-way flow, preventing the back flow.



- **60.2100.00** VNR-OHD G 1/4 FF brass **DN8**
- **60.2120.00** VNR-OHD G 3/8 FF brass **DN10**
- **60.2140.00** VNR-OHD G 1/2 FF brass **DN15**
- **60.2150.00** VNR-OHD G 3/4 FF brass **DN20**
- **60.2160.00** VNR-OHD G 1 FF brass **DN25**
- **60.2170.00** VNR-OHD G 1 1/4 FF brass **DN30**
- **60.2145.00** VNR-IHD G 1/2 FF S.S.T. Ai303 **DN15**



- Sturdy construction in S.S.T. and brass.
- O ring NBR (Nitrile)
- Return action of piston carried out by spring
- Minimum pressure loss.
- Rapid intervention at minimum flow variation
- Easy assembly

Technical specifications

Max temperature: 90°C

Part number	Rated pressure	Permissible pressure	Minimum pressure intervention	Flow rate	Inlet Outlet	Weight
	bar - MPa					
60.2100.00	280 - 28	310 - 31	0.2 – 0.02	25	G1/4 FF	114
60.2120.00	280 - 28	310 - 31	0.2 – 0.02	40	G3/8 FF	192
60.2140.00	280 - 28	310 - 31	0.2 – 0.02	80	G1/2 FF	446
60.2050.00	280 - 28	310 - 31	0.2 – 0.02	140	G3/4 FF	860,2
60.2160.00	280 - 28	310 - 31	0.2 – 0.02	200	G1 FF	1403,8
60.2170.00	280 - 28	310 - 31	0.2 – 0.02	450	G1 1/4 FF	2058,4
60.2145.00	350 - 35	390 - 39	0.2 – 0.02	80	G1/2 FF	544

Instruction manual, maintenance, installation, spare parts.

For a correct utilization, follow the directions of this manual

Re-print them on the Use and Maintenance booklet of the machine.

n. 12.9280.50

DIMENSIONAL DRAWING

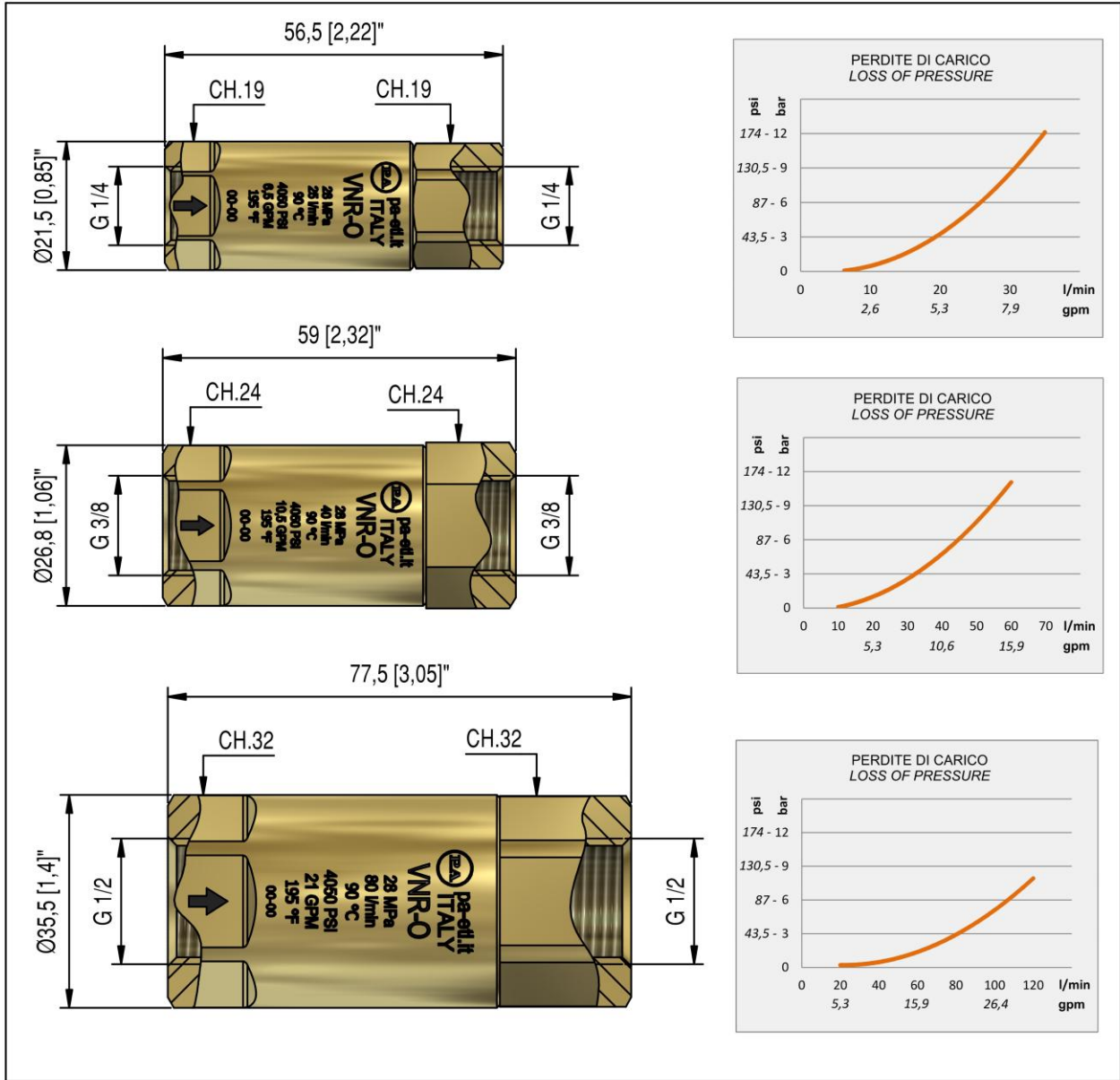

DN20

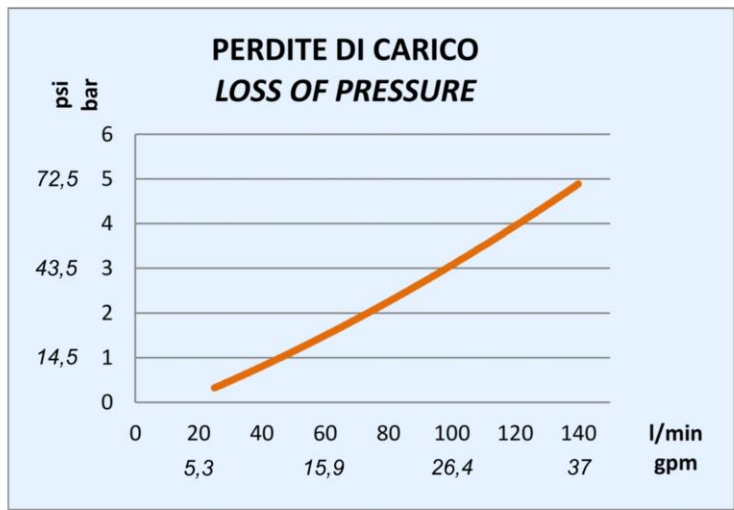
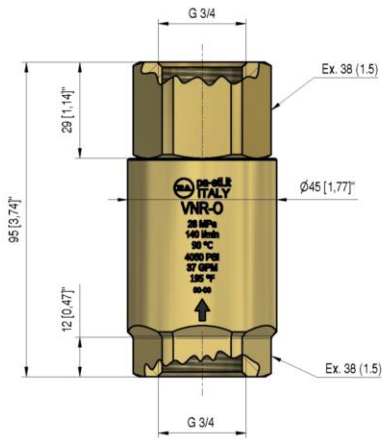

DN25

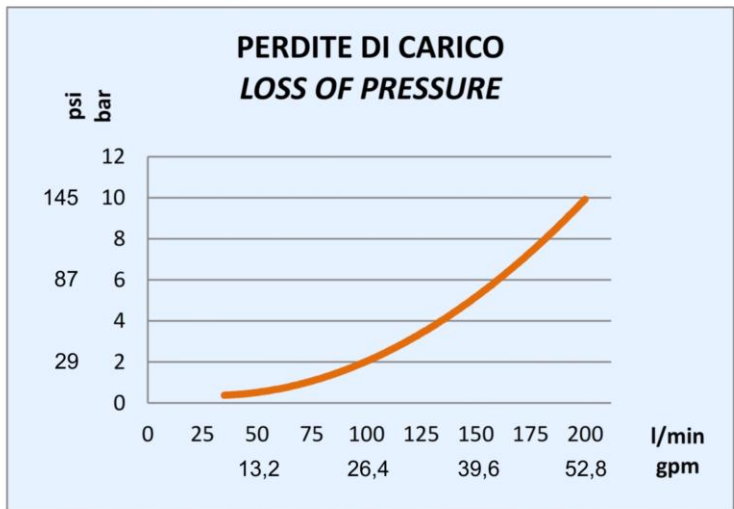
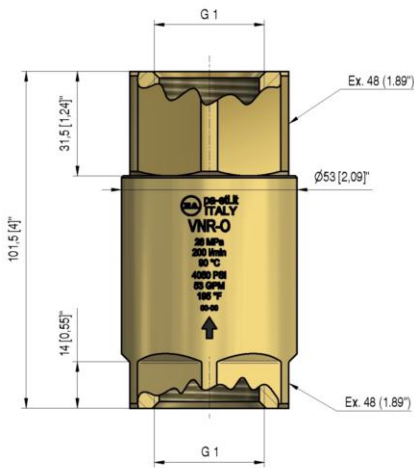

DN32

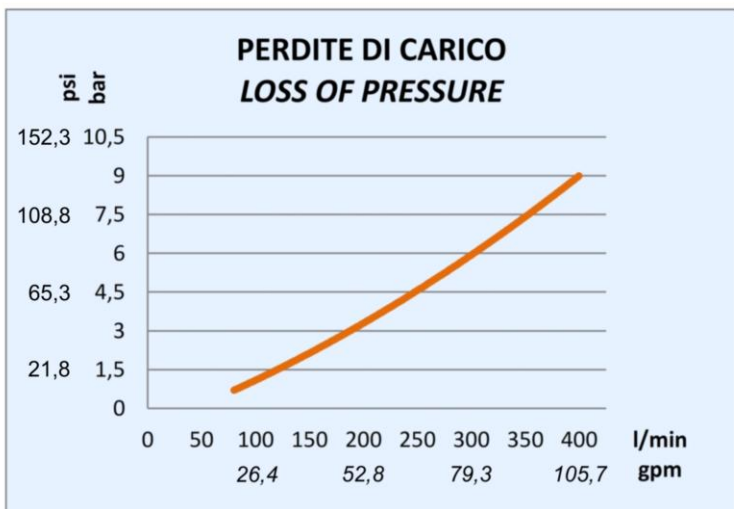
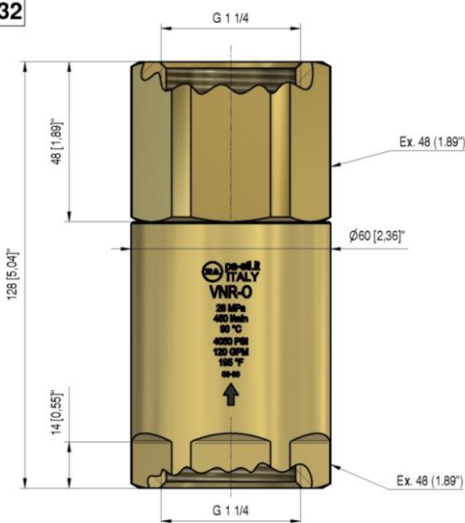

INSTRUCTIONS

SELECTION

This product is to be utilized with clean fresh water, even slightly additivated with normal detergents. For use involving different or corrosive liquids, contact the PA Technical department. Appropriate filtration should be installed when using unclean liquids. Choose the valve in line with the data of normal running (system rated pressure, max flow and max temperature). In any case, the pressure of the machine should not exceed the permissible pressure rate imprinted on the valve.

INSTALLATION

Make sure that the system is well proportioned. In particular, fit a piping system in line with the flow and pressure specifications. A bad proportioned system can ruin, without repair, all single components or damage the performance. This accessory, on a system that produces hot water, must be fitted in front of the heat generator. This product is bound to be incorporated on a finished machine. On a system that generates hot water, anticipate the fitting of accessories that limit the accidental increase of fluid temperature.

Always install a safety valve that protects the pressurized inlet channel.

ATTENTION: During assembly, respect the direction of the flow indicated on the valve.

The valve is designed to work in installations that remain always full of water. If it appears necessary to empty the part of the circuit downstream of the valve, it is advisable to adopt an apparatus that guarantees a gradual start of the pump or the filling of the circuit at low pressure.

OPERATIONS

Water flows freely in a one-way direction, while it is totally blocked in the opposite direction.

Hermetic sealing is ensured by Viton seals.

The internal construction allows a rapid conversion in case of back flow and low pressure drop.

PROBLEMS AND SOLUTIONS

PROBLEMS	PROBABLE CAUSES	SOLUTIONS
Valve leakage	Worn out seal Material matter in the seat Worn out seat	Replace Remove and clean Replace valve body
Slow closure	Valve not properly sized Piping too small	Change type of valve Replace

REGULATIONS

The Project and construction of our products comply with: norm CEI EN 60335-2-79 first edition, published 1999-03 and relative variations to the project of norm prEN1829.

Read this manual before starting the assembly

For a correct utilization, follow the directions described in this manual and re-print them on the Use and maintenance manual of the machine.

The present manual is valid for all valves named **VNR- OHD VNR- IHD**

MAINTENANCE

Maintenance has to be carried out by **Specialized Technicians.**

SPECIAL: every 800 working hours(circa 20,000 cycles), control the wear of the seals and internal parts.

ATTENTION: reassemble the valve in the correct manner paying special attention to the flow direction indicated on the valve.

.The manufacturer is not to be considered responsible for damage as a result from incorrect fitting and maintenance-

Technical data, descriptions and illustrations are indicative and liable to modification without notice

60.2100.00 VNR-OHD check valv. brass 1/4FF Bsp

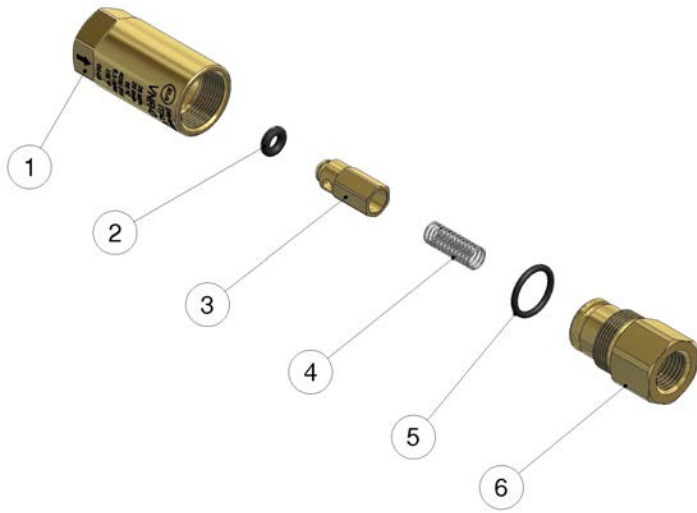

Po	P/N	Description	Q.ty	K	K	K	K	K	
1	60.2101.31	Coupling, 1/4 Bsp F x M18x1 F brass	1						3
2	10.3125.00	O-ring, 2,5x4 mm	1						10
3	60.0859.99	Shutter pin, brass+or 2,5x4 mm N	1						10
4	60.0867.51	Spring, 0,5x6,5x22 mm Sst.	1						10
5	10.3060.01	O-ring, 1,78x12,42 mm Ni 85	1						10
6	60.2102.31	Shutter coupl., 1/4F Bsp brass	1						3

60.2120.00 VNR-OHD check valv. brass 3/8FF Bsp

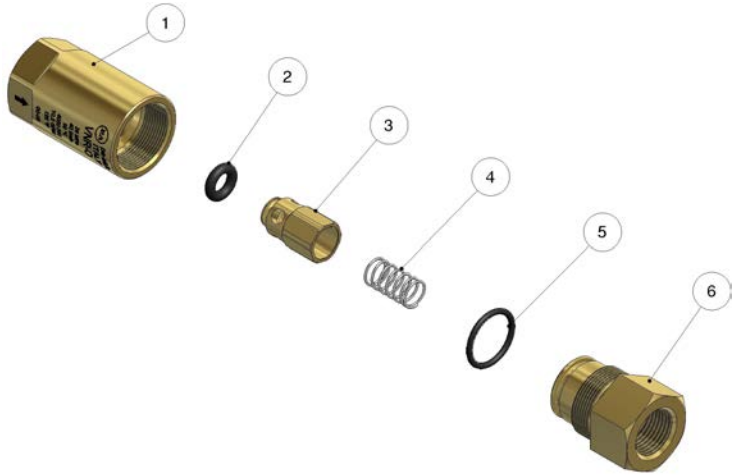

Po	P/N	Description	Q.ty	K	K	K	K	K	
1	60.2121.31	Coupling, 3/8 Bsp F x M22x1 F brass	1						3
2	10.3213.00	O-ring, 3x6 mm	1						10
3	60.0052.99	Shutter pin, brass+o-ring 3x6 mm	1						10
4	60.0053.51	Spring, 0,7x9x20 mm Sst.	1						10
5	10.3066.01	O-ring, 1,78x15,6 mm Ni 85	1						10
6	60.1811.31	Shutter coupl., 3/8F Bsp brass	1						5

60.2140.00 VNR-OHD check valv. brass 1/2FF Bsp

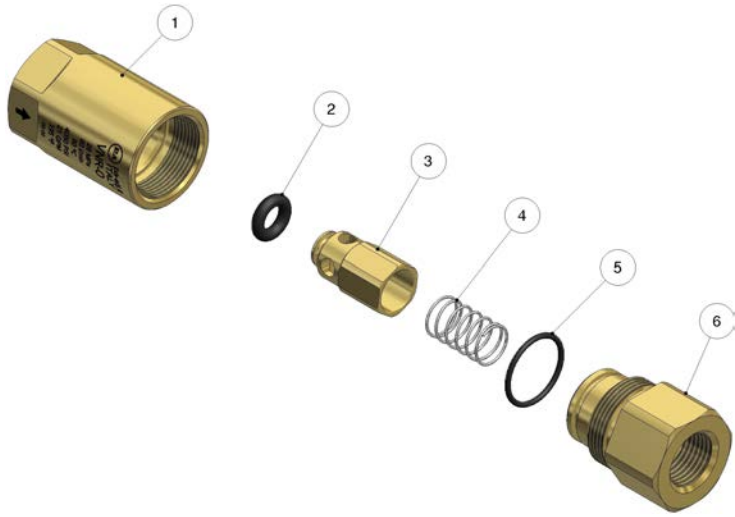

Po	P/N	Description	Q.ty	K	K	K	K	K	📦
1	60.2141.31	Coupling, 1/2 Bsp F x M30x1,5F brass	1						3
2	10.3292.00	O-ring, 4x8 mm	1						10
3	60.0488.99	Shutter pin, brass+or 4x8 mm	1						10
4	60.0489.51	Spring, 0,8x13,3x27 mm Sst.	1						5
5	10.3072.60	O-ring, 1,78x21,95 mm Ni 85	1						10
6	60.2809.31	Shutter coupl., 1/2F Bsp brass	1						3

60.2145.00 VNR-IHD check valv. sst 1/2FF Bsp

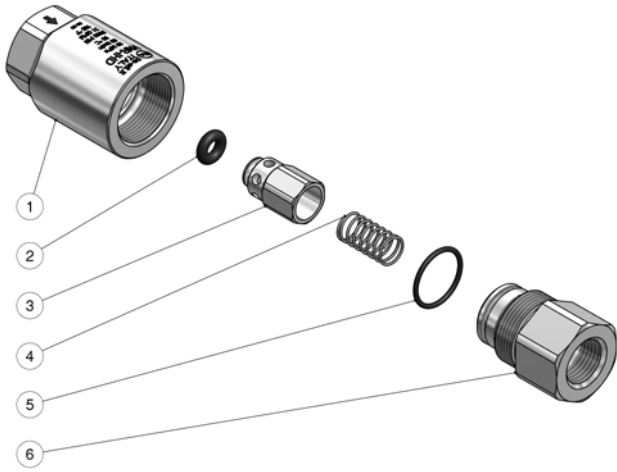

Po	P/N	Description	Q.ty	K	K	K	K	K	
1	60.2147.51	Sst. seat 1/2 Bsp F x M30x1,5F	1						3
2	10.3292.08	O-ring, 4x8 mm Ni 85	1						10
3	60.8020.51	Pin, hex.17 Sst	1						3
4	60.8007.51	Spring, 0,8x12,2x27 mm Sst.	1						3
5	10.3072.60	O-ring, 1,78x21,95 mm Ni 85	1						10
6	60.2146.51	Sst. coupling, 1/2 Bsp F x M30x1,5 M	1						3

60.2150.00 VNR-OHD check valv. brass 3/4 FF Bsp

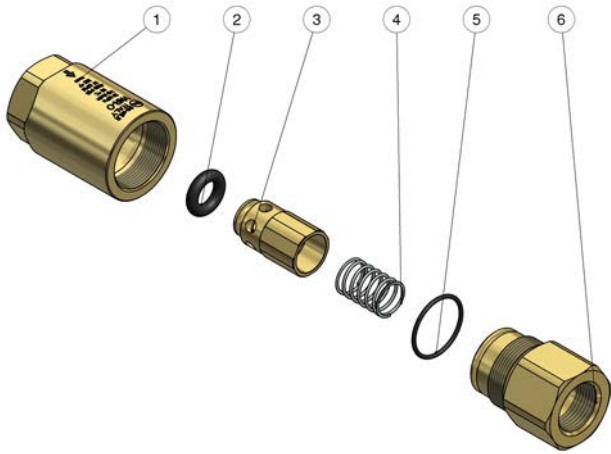

Po	P/N	Description	Q.ty	K	K	K	K	K	
1	60.2151.31	Coupling, 3/4 Bsp F x M35x1,5 F brass	1						3
2	10.3314.00	O-ring, 5,33x12,06 mm	1						10
3	60.5012.99	Shutter pin, brass+or 5,33x12,06 mm	1						5
4	60.5013.51	Spring, 1,3x18x29 mm Sst.	1						10
5	10.3077.08	O-ring, 1,78x28,3 mm Ni 85	1						10
6	60.4802.31	Coupling, 3/4" Bsp F brass	1						3

60.2160.00 VNR-OHD check valv. brass 1" FF Bsp

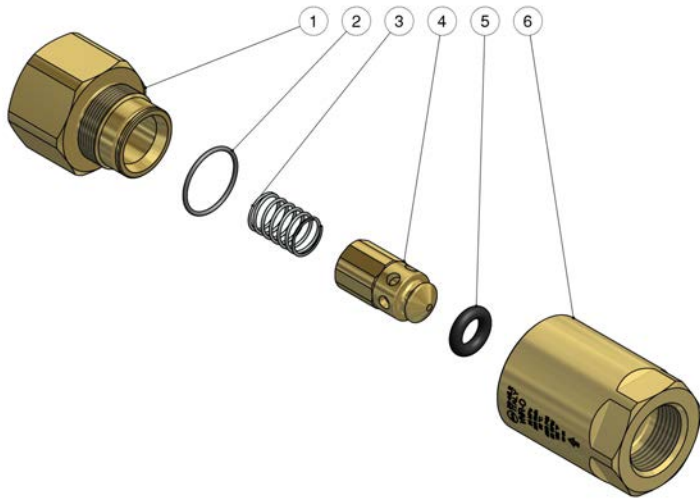

Po	P/N	Description	Q.ty	K	K	K	K	K	
1	60.4303.31	Shutter coupl., 1" Bsp F brass	1						1
2	10.3077.08	O-ring, 1,78x28,3 mm Ni 85	1						10
3	60.5013.51	Spring, 1,3x18x29 mm Sst.	1						10
4	60.5012.99	Shutter pin, brass+or 5,33x12,06 mm	1						5
5	10.3314.00	O-ring, 5,33x12,06 mm	1						10
6	60.2161.31	Coupling, 1" Bsp F x M35x 1,5 F brass	1						3

60.2170.00 VNR-OHD check valv. brass 1"1/4 FF Bsp

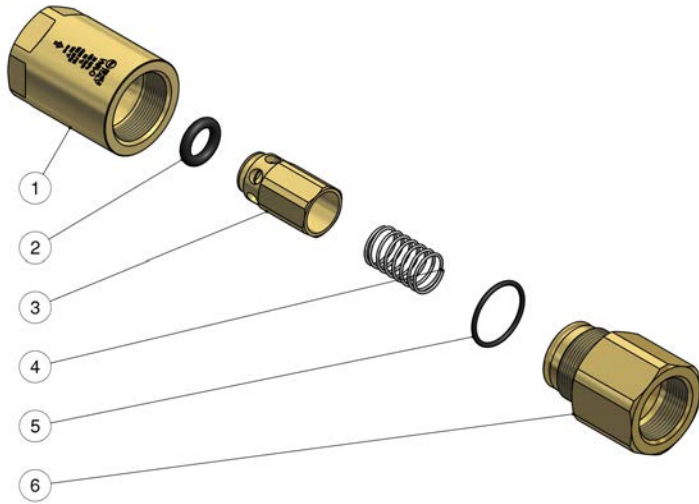

Po	P/N	Description	Q.ty	K	K	K	K	K	
1	60.2171.31	Coupling, 1"1/4 Bsp F x M45x 2 F	1						3
2	10.3350.00	O-ring, 6x18 mm	1						10
3	60.4012.31	Check valve	1						3
4	60.4013.51	Spring, 1,6x23,1x44mm	1						3
5	10.3208.28	O-ring, 2,62x36,17 mm Ni85	1						5
6	60.4014.31	Piston holder, 1"1/4 Bsp F	1						3